

B ✓  
ORIGINAL

IN THE UNITED STATES DISTRICT COURT  
FOR THE NORTHERN DISTRICT OF TEXAS  
DALLAS DIVISION

U.S. DISTRICT COURT  
NORTHERN DISTRICT OF TEXAS  
**FILED**  
DEC 10 2007  
CLERK, U.S. DISTRICT COURT  
By DP  
Deputy

HEELING SPORTS LIMITED,

*Plaintiff,*

v.

ALDI, INC.

*Defendant.*

§  
§  
§  
§  
§  
§  
§  
§  
§

Civil Action No. 17303

**307 CV 2057 AB**

**JURY TRIAL DEMANDED**

**PLAINTIFF'S ORIGINAL COMPLAINT  
FOR PATENT INFRINGEMENT**

Plaintiff Heeling Sports Limited ("Heeling") files this Complaint against defendant Aldi, Inc. ("Aldi") and alleges as follows:

**PARTIES**

1. Plaintiff Heeling is a limited partnership organized and existing under the laws of the State of Illinois and having a principal place of business at 3200 Belmeade Dr., Suite 100, Carrollton, Texas 75006.

2. On information and belief, Aldi is an Illinois corporation with a place of business at 1200 North Kirk Road, Batavia, IL 60510.

**JURISDICTION AND VENUE**

3. This action for patent infringement arises under the patent laws of the United States, Title 35 U.S.C. §§ 101 *et seq.* This Court has subject matter jurisdiction over this action pursuant to 28 U.S.C. §§ 1331 and 1338(a).

4. Upon information and belief, this Court has personal jurisdiction over Aldi because Aldi is a corporation that regularly conducts business within the State of Texas and within this judicial district.

5. Venue is proper in this district pursuant to 28 U.S.C. §§ 1391(c).

### **FACTUAL BACKGROUND**

6. Heeling was founded in Carrollton, Texas in 2000, and is in the business of designing, manufacturing and distributing wheeled footwear. Heeling developed and patented the internationally famous HEELYS brand wheeled footwear.

7. Since their introduction in December 2000, HEELYS wheeled footwear (also referred to as HEELYS skates) have become tremendously popular and commercially successful in the United States and in numerous countries around the world.

8. HEELYS skates are unique and innovative in many respects. HEELYS skates have at least one wheel in the heel, and are used by walking or running on the forefoot and transitioning to rolling on the wheel or wheels in the sole. Some models of HEELYS skates have two wheels in the sole, including one wheel in the heel and another wheel positioned forward of the wheel in the heel. The HEELYS skates are dual-purpose footwear that incorporate one or more stealth wheels in the heel that allow a user to seamlessly transition from walking or running to rolling by shifting weight to the one or more wheels in the sole.

9. Heeling's innovations in the HEELYS skates are protected by a portfolio of patents, both in the United States and in numerous countries around the world.

10. On June 18, 2002 Heeling received United States Patent No. 6,406,038 ("the '038 Patent"), attached hereto as exhibit A, entitled "Heeling Apparatus and Method." The '038

Patent was duly and legally issued to Heeling as the assignee of the inventors' entire right, title, and interest in the '038 Patent. The '038 Patent is valid, subsisting and in full force and effect.

11. On May 25, 2004 Heeling received United States Patent No. 6,739,602 ("the '602 Patent"), attached hereto as exhibit B, entitled "Heeling Apparatus and Method." The '602 Patent was duly and legally issued to Heeling as the assignee of the inventors' entire right, title, and interest in the '602 Patent. The '602 Patent is valid, subsisting and in full force and effect.

12. On June 8, 2004 Heeling received United States Patent No. 6,746,026 ("the '026 Patent"), attached hereto as exhibit C, entitled "Heeling Apparatus and Method." The '026 Patent was duly and legally issued to Heeling as the assignee of the inventors' entire right, title, and interest in the '026 Patent. The '026 Patent is valid, subsisting and in full force and effect.

13. At all relevant times Heeling has been and is now the sole and exclusive assignee and owner of all right, title, and interest to the '038, '602 and '026 Patents.

14. Heeling has not granted Aldi any license or permission to use or exploit any of its patents, including the '038, '602 and the '026 Patents.

15. Aldi is selling infringing knockoffs of HEELYS.

**COUNT I**  
**Infringement of the '038 Patent**

16. Heeling realleges and incorporates by reference the allegations of paragraphs 1-15 above.

17. Upon information and belief, Aldi and/or its agents willfully encourage purchasers of infringing skates to use them just like HEELYS skates.

18. Purchasers and users of the infringing skates directly infringe the '038 Patent by using the skates in accordance with the claimed invention of the '038 Patent and equivalents thereof.

19. Upon information and belief, Aldi is infringing the '038 Patent, in this judicial district and elsewhere in the United States, by actively inducing the infringement of others. Upon information and belief, in addition to offering infringing skates for sale, Aldi and/or its agents advise purchasers of the infringing skates to use them like the HEELYS skates and provide instructions to purchasers and users of the skates describing how to use them in accordance with the claimed invention of the '038 Patent and equivalents thereof.

20. As a direct and proximate result of Aldi's infringement of the '038 Patent, Heeling has suffered substantial harm and damages in amounts that are presently undetermined.

21. Unless Aldi and all of those acting in concert and all those aiding or abetting Aldi and its employees, agents or the like are permanently enjoined by this Court, the '038 Patent will continue to be infringed. Aldi's infringing acts will cause irreparable harm to Heeling for which it has no adequate remedy at law.

**COUNT II**  
**Infringement of the '602 Patent**

22. Heeling realleges and incorporates by reference the allegations of paragraphs 1-15 above.

23. Upon information and belief, Aldi has been and is willfully infringing the '602 Patent by using, offering to sell, selling, and/or importing within and into the United States, and inducing others to use within the United States, products and/or methods that infringe the '602 Patent. Unless enjoined by the Court, Aldi will continue to infringe and induce infringement of the '602 Patent.

24. As a direct and proximate result of Aldi's infringement of the '602 Patent, Heeling has suffered substantial harm and damages in amounts that are presently undetermined.

25. Unless Aldi and all of those acting in concert and all those aiding or abetting Aldi and its employees, agents or the like are permanently enjoined by this Court, the '602 Patent will continue to be infringed. Aldi's infringing acts will cause irreparable harm to Heeling for which it has no adequate remedy at law.

**COUNT III**  
**Infringement of the '026 Patent**

26. Heeling realleges and incorporates by reference the allegations of paragraphs 1-15 above.

27. Upon information and belief, Aldi has been and is, willfully infringing the '206 Patent by using, offering to sell, selling, and/or importing within and into the United States, and inducing others to use within the United States, products and/or methods that infringe the '206 Patent. Unless enjoined by the Court, it will continue to infringe and induce infringement of the '206 Patent.

28. As a direct and proximate result of Aldi's infringement of the '206 Patent, Plaintiff Heeling has suffered substantial harm and damages in amounts that are presently undetermined.

29. Unless Aldi and all of those acting in concert and all those aiding or abetting Aldi and its employees, agents or the like are permanently enjoined by this Court, the '206 Patent will continue to be infringed. Aldi's infringing acts will cause irreparable harm to Heeling for which it has no adequate remedy at law.

**PRAYER**

WHEREFORE, Heeling prays for the following:

A. Judgment that Aldi has infringed and has actively induced others to infringe the '038, '602 and '026 Patents.

B. Preliminary and permanent injunctive relief pursuant to 35 U.S.C. § 283

prohibiting Aldi, including its employees, agents, affiliates, and servants, and all other persons in active concert or participation with it, including those aiding and abetting Aldi, from infringing and inducing the infringement of the '038, '602 and '026 Patents;

- C. That Aldi, and all those that have acted in concert or aided and abetted Aldi, including its agents, affiliates, servants, and employees, and all other persons in active concert or participation with them, including those aiding and abetting Aldi, be ordered to submit to the Court a sworn, written report detailing the manner of their compliance with the requested injunctive relief;
- D. An award of damages pursuant to 35 U.S.C. § 284 to compensate Heeling for Aldi's infringement and inducement of infringement of the '038, '602 and '026 Patents, together with pre-judgment and post-judgment interest;
- E. Judgment that the damages so adjudged be trebled pursuant to 35 U.S.C. § 284 due to Aldi's willful infringement;
- F. Judgment that this is an exceptional case pursuant to 35 U.S.C. § 285 and that Heeling be awarded its attorney fees, costs, and expenses incurred in this action;
- G. A full and complete inspection of business records, including records relating to import and export of relevant products, in support of Heeling's claim for an accounting; and
- I. Such other and further relief as the Court may deem just and proper.

**DEMAND FOR JURY TRIAL**

Heeling hereby demands a trial by jury of all issues so triable in this action.

Dated: December 10, 2007.

Respectfully submitted,



**Craig B. Florence**

Attorney-in-Charge

Texas Bar No. 07158010

[cflorence@gardere.com](mailto:cflorence@gardere.com)

Thomas C. Wright

Texas Bar No. 24028146

[twright@gardere.com](mailto:twright@gardere.com)

GARDERE WYNNE SEWELL, L.L.P.

1601 Elm Street, Suite 3000

Dallas, Texas 75201

Telephone: (214) 999-3000

Facsimile: (214) 999-4667

**ATTORNEYS FOR PLAINTIFF  
HEELING SPORTS LIMITED**

**EXHIBIT "A"**



US00640602

(12) **United States Patent**  
Adams

(10) **Patent No.:** US 6,406,038 B2  
(45) **Date of Patent:** Jun. 18, 2002

(54) **HEELING APPARATUS AND METHOD**

(75) **Inventor:** Roger R. Adams, The Colony, TX (US)

(73) **Assignee:** Heeling Sports Limited, Carrollton, TX (US)

(\* ) **Notice:** Subject to any disclaimer, the term of this patent is extended or adjusted under 35 U.S.C. 154(b) by 0 days.

(21) **Appl. No.:** 09/930,318

(22) **Filed:** Aug. 14, 2001

CA	2258978	7/1999	.....	A63C/17/20
CA	2258980	7/1999	.....	A63C/17/20
DE	254775	5/1912	.....	
DE	456796	3/1928	.....	280/843
DE	723 266 A1 *	6/1942	.....	280/11.25
DE	821323	7/1949	.....	
DE	197 55 340 A1	6/1999	.....	A63C/17/20
FR	1194886 A	4/1958	.....	
FR	2196826	3/1974	.....	A63C/17/20
GB	2297	of 1877	.....	280/11.24
GB	117176	9/1917	.....	
GB	150512 A	8/1919	.....	
GB	216903 A	6/1924	.....	
GB	296 13 508 U1	8/1996	.....	A63C/17/00
KR	90-11303	3/1988	.....	
WO	PCT/US97/11652	7/1997	.....	A43B/23/00
WO	98/01051	1/1998	.....	A43B/23/00

**Related U.S. Application Data**

- (62) Division of application No. 09/540,125, filed on Mar. 31, 2000.
- (60) Provisional application No. 60/127,459, filed on Apr. 1, 1999.
- (51) **Int. Cl.<sup>7</sup>** ..... A63C 17/08
- (52) **U.S. Cl.** ..... 280/11.24; 280/11.19; 280/11.25; 36/115; 301/5.301
- (58) **Field of Search** ..... 280/11.24, 11.19, 280/11.25, 11.226, 11.232, 841; 36/115, 116; 301/5.301, 5.303, 5.305

**References Cited**

**U.S. PATENT DOCUMENTS**

- 132,474 A 10/1872 Lindley
- 202,191 A 4/1878 Proctor
- 234,030 A 11/1880 Hadley et al.

(List continued on next page.)

**FOREIGN PATENT DOCUMENTS**

- AT 309567 A 10/1918 ..... 280/11.227
- CA 1 138 194 6/1980 ..... A43B/5/00
- CA 1 239 017 3/1983 ..... A43B/5/00

**OTHER PUBLICATIONS**

Article in "Bulletin Board," Digital bytes and buzz, which contains an ad for "Street Flyers."  
 Advertisement for "Street Flyers" at the Internet website for FAO Schwartz, [www.fao.com/faoschwarz/streetflyers.html](http://www.fao.com/faoschwarz/streetflyers.html) dated Dec. 17, 1999.  
 Advertisement for "Street Flyers" at the Internet website for StreetFlyers, [www.streeflyers.com/cgi-bin/ncommerce3/ExecMacro/home.d2w/report](http://www.streeflyers.com/cgi-bin/ncommerce3/ExecMacro/home.d2w/report) dated Jan. 24, 2000.

*Primary Examiner*—Robert P. Olszewski  
*Assistant Examiner*—James S. McClellan  
 (74) *Attorney, Agent, or Firm*—Robert J. Ward

(57) **ABSTRACT**

A heeling apparatus includes a shoe with a unique feature in the heel that allows one to walk, run, or roll seamlessly. The appearance is that of normal footwear because of the covert wheel assembly. The stealth wheel in the heel gives one the ability to roll or slide in areas you could only walk. Heeling is a new activity that employs a unique method of rolling and requires a newly learned skill set of balance, positioning, and coordination.

27 Claims, 10 Drawing Sheets

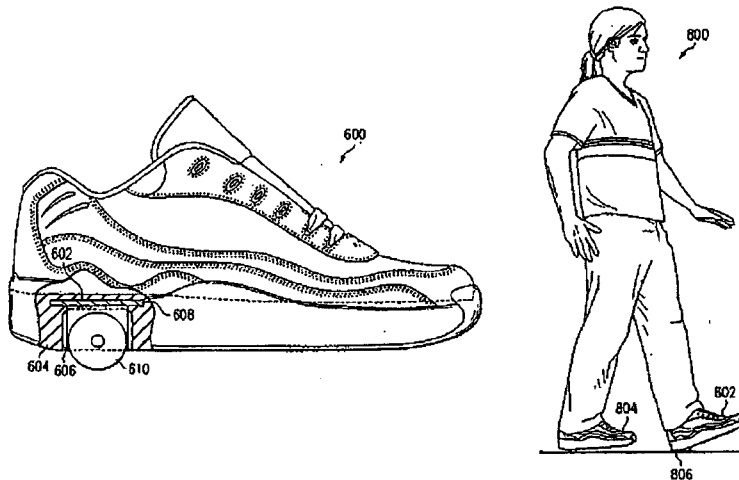

U.S. PATENT DOCUMENTS

579,577 A	3/1897	Hanscom	4,442,614 A *	4/1984	Farberov	36/103
702,476 A	6/1902	Price	4,496,025 A	1/1985	Gattman	182/121
875,560 A	12/1907	Vaughan	4,523,767 A	6/1985	Le Page	280/11.19
881,079 A	3/1908	Jolitz	4,638,575 A	1/1987	Illustrato	36/38
892,152 A	6/1908	Harman	4,676,010 A	6/1987	Cheskin	36/32 R
966,821 A	8/1910	Gaw	4,691,453 A	9/1987	Tifre	36/8.3
1,051,880 A	2/1913	Glenn	4,699,390 A *	10/1987	Cole	280/11.19
1,056,091 A	3/1913	Dickson	4,763,909 A	8/1988	Bergeron	280/11.25
1,068,575 A	* 7/1913	Demorey et al.	4,783,910 A	11/1988	Boys, II et al.	36/107
1,189,329 A	7/1916	Winagle	4,795,181 A	1/1989	Armstrong	280/87.04 A
1,260,901 A	3/1918	Hayhurst	4,817,974 A	4/1989	Bergeron	280/11.2
1,369,849 A	* 3/1921	Spencer	4,841,648 A	6/1989	Shaffer et al.	36/43
1,428,232 A	9/1922	Holmen	4,843,741 A	7/1989	Ying-Mao	36/114
1,592,692 A	7/1926	Hackett	D302,994 S	8/1989	Hawkes et al.	D21/227
1,600,075 A	9/1926	Stoops	4,887,824 A	12/1989	Zatlin	280/87.042
1,636,909 A	7/1927	Haney	4,897,939 A	2/1990	Harrington	36/108
1,866,006 A	7/1932	Bergstrand	4,928,982 A	5/1990	Logan	280/11.22
1,975,661 A	10/1934	Powell	4,947,560 A	8/1990	Fuerst et al.	36/88
1,984,989 A	12/1934	Reed	4,977,691 A	12/1990	Orchard	36/44
2,060,391 A	11/1936	Castagnola	4,988,122 A	1/1991	Saunders	280/841
2,095,942 A	10/1937	Wetterstrand	5,056,240 A	10/1991	Sherrill	36/7.3
2,113,477 A	4/1938	Gilman	5,134,791 A	8/1992	Gregory	36/107
2,114,461 A	4/1938	Agosta et al.	5,249,376 A	10/1993	Capria	36/115
2,114,790 A	4/1938	Venables	D341,179 S *	11/1993	Evans, III	D21/763
2,138,823 A	12/1938	Werkman	5,286,043 A	2/1994	Tkaczyk	280/11.22
2,165,581 A	* 1/1939	Schroeder	5,319,866 A	6/1994	Foley et al.	36/91
D117,918 S	12/1939	Brodick	5,319,869 A	6/1994	McDonald et al.	36/114
D146,368 S	* 2/1947	McCaffrey	D352,818 S	11/1994	Bailey	D2/919
2,422,228 A	6/1947	Ferrar	5,384,973 A	1/1995	Lyden	36/25 R
2,476,806 A	7/1949	Brandt, Jr.	5,388,350 A	2/1995	Parker, Jr.	36/115
2,484,935 A	10/1949	De Rooy	5,392,537 A	2/1995	Goldberg	36/134
2,490,469 A	12/1949	Pittman	5,393,077 A	2/1995	Wanous	280/7.13
D161,557 S	* 1/1951	Walker et al.	5,396,675 A	3/1995	Vincent et al.	12/142 P
2,572,671 A	10/1951	Shaw	5,398,970 A	3/1995	Tucky	280/841
2,723,467 A	11/1955	Cassidy	5,410,821 A	5/1995	Hilgendorf	36/100
2,897,609 A	8/1959	Bodkin	5,417,444 A	5/1995	Chen	280/87.042
3,010,732 A	* 11/1961	Correll	5,425,186 A	6/1995	Hoyt	36/97
3,027,661 A	4/1962	McCord	5,511,824 A	4/1996	Kim	280/841
3,032,894 A	5/1962	Kennedy et al.	5,527,049 A *	6/1996	Ortiz	188/5
3,112,119 A	11/1963	Sweet	5,527,050 A	6/1996	Szendel	280/11.22
3,176,416 A	4/1965	Seegert	D373,674 S	9/1996	Dolinsky	D2/956
3,306,623 A	2/1967	Weitzner	5,572,804 A	11/1996	Skaja et al.	36/29
3,351,353 A	11/1967	Weitzner	5,595,004 A	1/1997	Lyden et al.	36/29
3,374,002 A	* 3/1968	Lewis	5,632,104 A	5/1997	Zohar	36/88
3,476,399 A	* 11/1969	Finn	5,638,614 A	6/1997	Hardy	36/113
3,478,447 A	* 11/1969	Gillead	5,655,316 A	8/1997	Huang	36/132
3,486,250 A	12/1969	Purle	5,682,685 A	11/1997	Terlizzi	36/8.3
3,789,523 A	2/1974	Rubin	5,697,643 A	12/1997	Marasco et al.	280/825
D231,999 S	7/1974	Engman	5,716,074 A	2/1998	Theodorou	280/843
D233,619 S	* 11/1974	Kelling	5,716,723 A	2/1998	Van Cleef et al.	428/690
3,876,217 A	4/1975	Copier	5,730,467 A	3/1998	Huang	280/843
3,884,485 A	5/1975	Walle	5,769,432 A *	6/1998	Tybinkowski et al.	280/11.204
3,934,359 A	1/1976	Fletcher	5,785,327 A	7/1998	Gallant	280/11.27
3,963,251 A	6/1976	Miano	5,797,609 A	8/1998	Fichespain	280/11.19
3,983,643 A	10/1976	Schreyer et al.	5,823,913 A	10/1998	Aruin et al.	482/4
3,997,179 A	* 12/1976	de Blois	5,836,591 A	11/1998	Roderick et al.	280/11.22
4,088,334 A	5/1978	Johnson	5,839,737 A	11/1998	Kruczek	280/11.115
4,095,817 A	6/1978	Cohen	D401,739 S	12/1998	James	D2/946
D250,492 S	12/1978	Kish	D402,797 S *	12/1998	Kracke	D2/948
4,133,548 A	1/1979	Smith	D404,550 S	1/1999	James	D2/960
4,138,127 A	2/1979	Kimmell et al.	5,881,413 A	3/1999	Throneburg et al.	12/133 B
4,149,735 A	4/1979	Blackburn et al.	5,882,018 A	3/1999	Petrosino	280/7.13
4,150,497 A	4/1979	Weber	5,885,500 A	3/1999	Tawney et al.	264/154
4,183,547 A	1/1980	Cohen et al.	5,887,898 A	3/1999	Petrosino	280/825
4,245,406 A	1/1981	Landay et al.	D408,123 S	4/1999	James	D2/969
4,295,655 A	10/1981	Landay et al.	5,927,729 A	7/1999	Di Filippo et al.	280/11.3
4,303,253 A	12/1981	Rottenkolber	5,927,734 A	7/1999	Horton, II et al.	280/87.042
4,316,334 A	2/1982	Hunt	D412,778 S	8/1999	James	D2/951
4,364,187 A	12/1982	Melendez	D412,779 S	8/1999	James	D2/957
4,417,737 A	11/1983	Suroff	D413,193 S	8/1999	James	D2/947
			5,951,049 A	9/1999	Calverey et al.	280/825

US 6,406,038 B2

Page 3

5,967,552 A	10/1999	Roderick et al. ....	280/843	6,151,806 A	11/2000	Morris et al. ....	36/136
5,970,631 A	10/1999	Inman .....	36/115	6,158,150 A	12/2000	Morris et al. ....	36/115
5,997,105 A	12/1999	Wu .....	301/124.1	6,195,918 B1	3/2001	Kelley et al. ....	36/115
6,006,450 A	12/1999	Hayes .....	36/107	6,195,920 B1	3/2001	Morris et al. ....	36/132
6,006,451 A	12/1999	Morris et al. ....	36/115	6,213,480 B1 *	4/2001	Rodriguez .....	280/11.204
6,041,525 A	3/2000	Kelley .....	36/115	6,226,900 B1	5/2001	Mazars .....	36/132
6,050,357 A	4/2000	Staelin et al. ....	180/65.1	6,243,972 B1	6/2001	De France .....	36/117.1
6,061,930 A	5/2000	Zinovieff .....	36/115	6,247,251 B1	6/2001	James .....	36/115
6,070,887 A	6/2000	Cornelius et al. ....	280/11.27	6,247,708 B1	6/2001	Hsu .....	
6,092,305 A	7/2000	Troy et al. ....	36/3 B	6,250,656 B1	6/2001	Ibarra .....	280/87.041
6,115,946 A	9/2000	Morris et al. ....	36/115	6,308,964 B1	10/2001	Chang .....	
6,120,039 A	9/2000	Clementi .....	280/11.19				
D433,214 S	11/2000	McDowell .....	D2/957				

\* cited by examiner

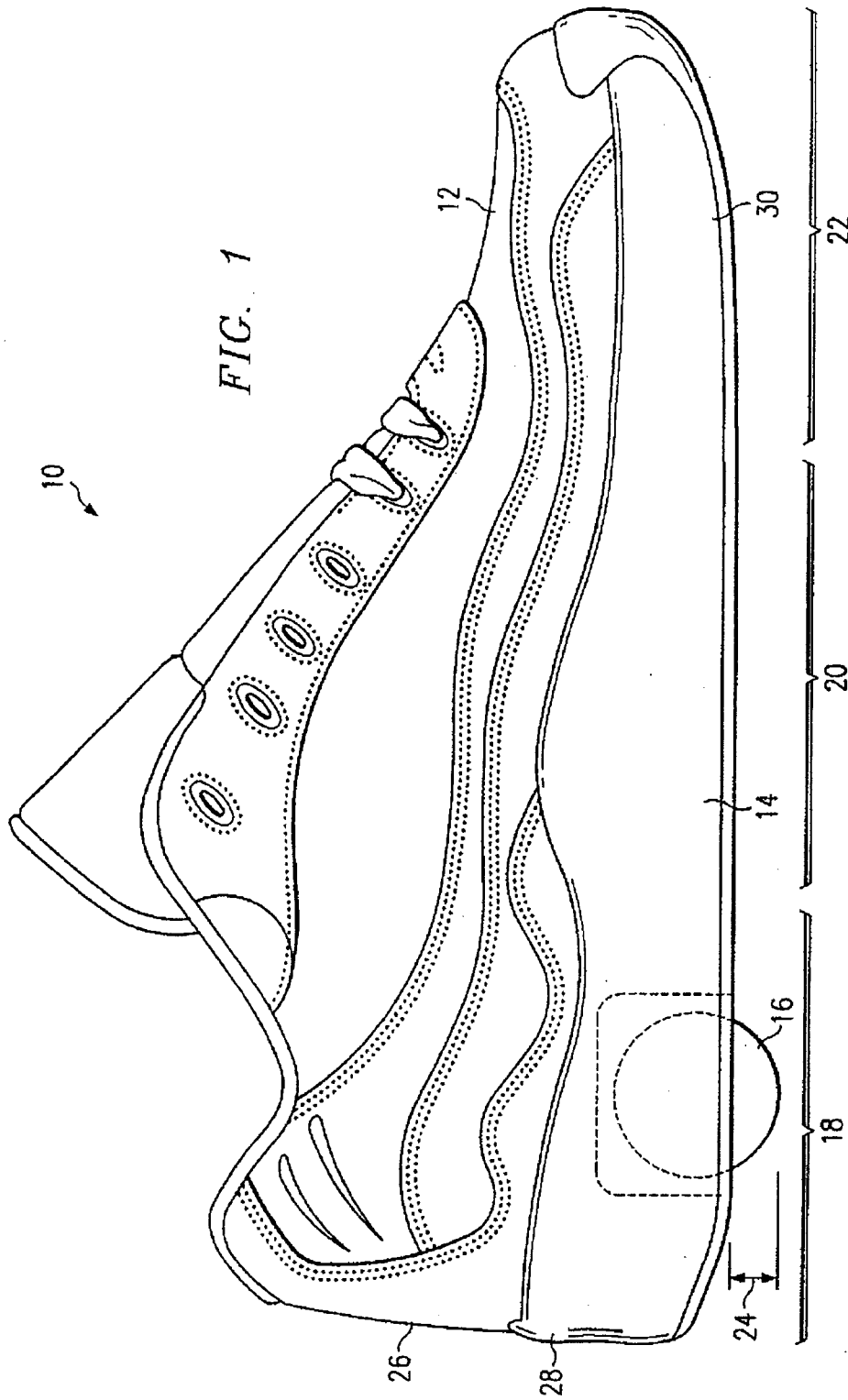

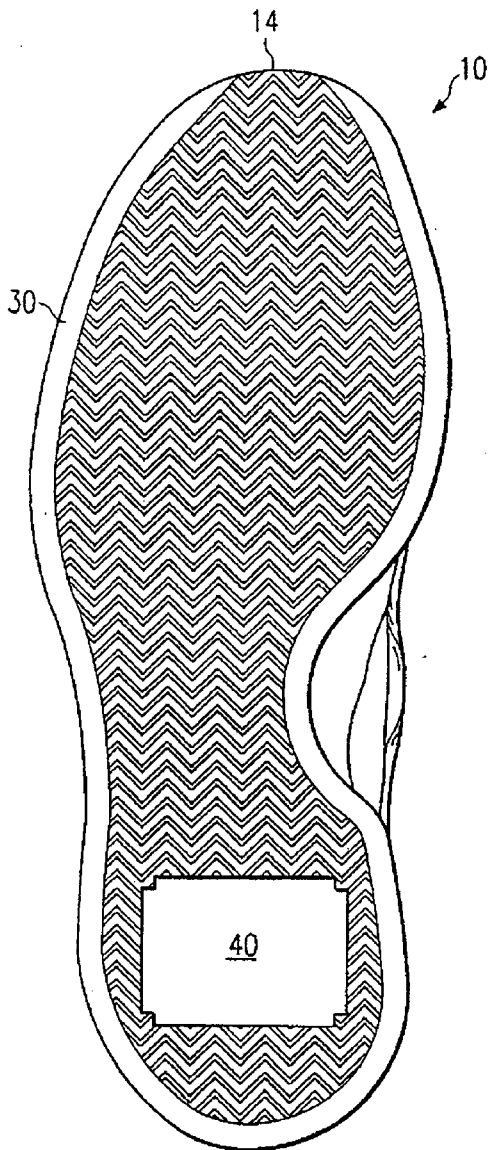

FIG. 2A

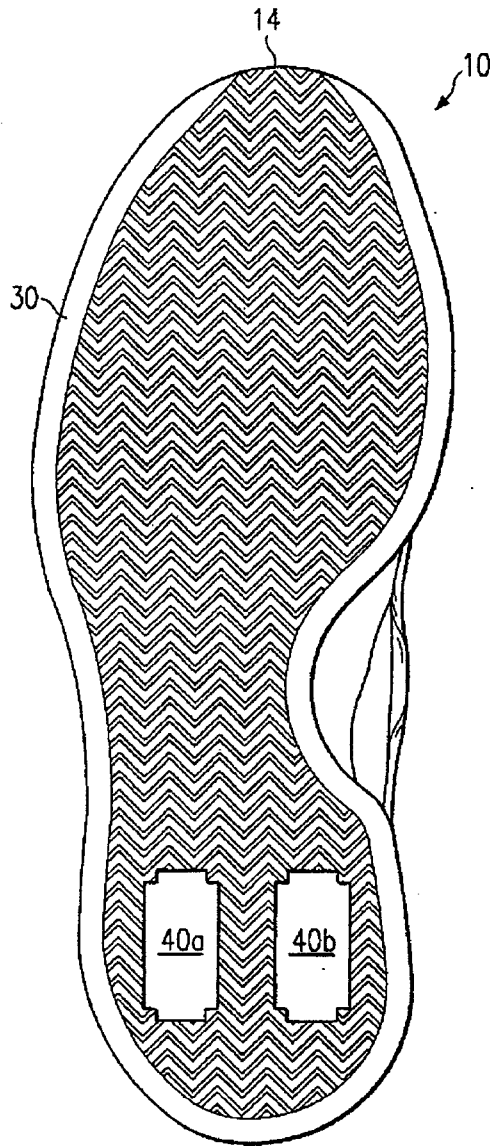

FIG. 2B

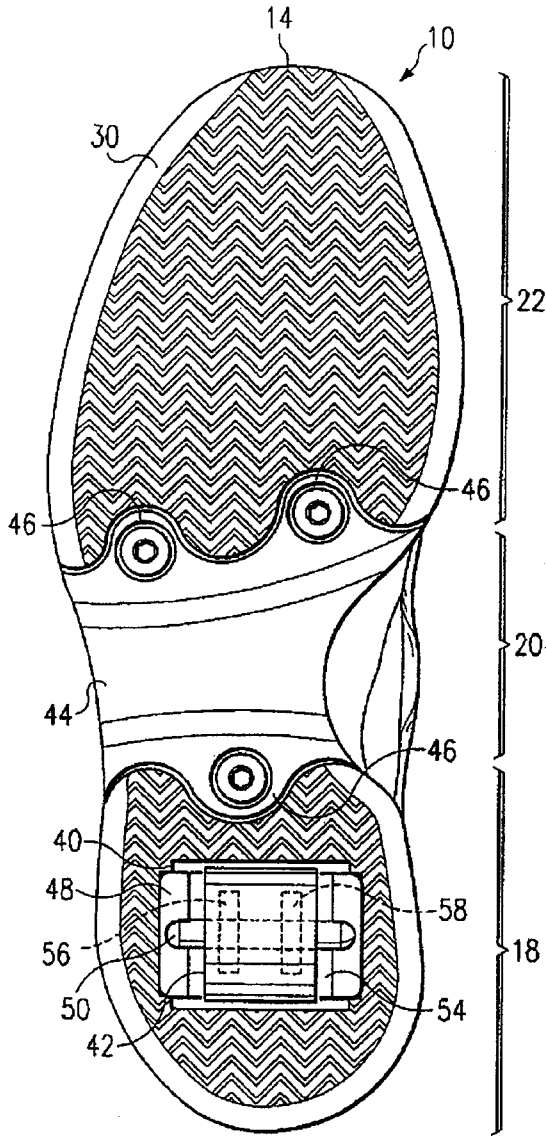

FIG. 3A

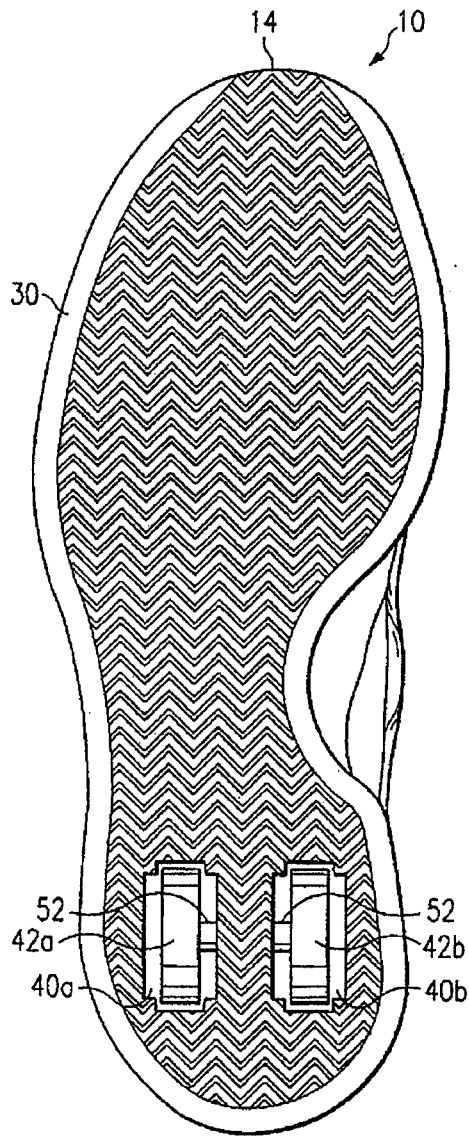

FIG. 3B

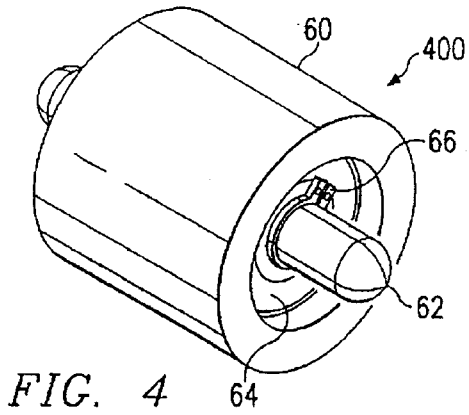

FIG. 4

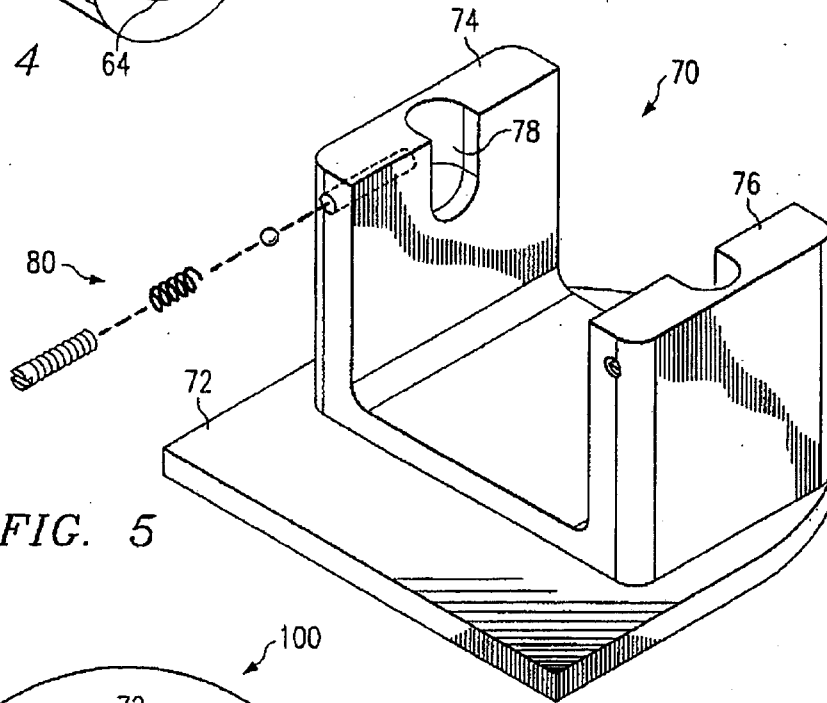

FIG. 5

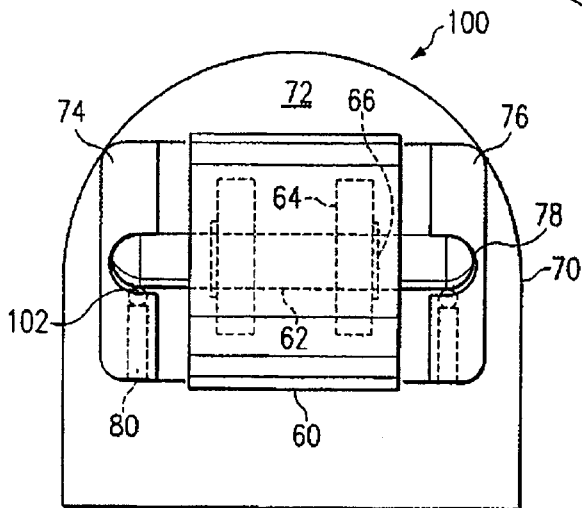

FIG. 6

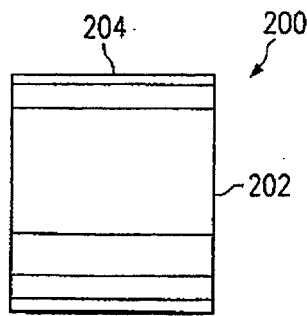
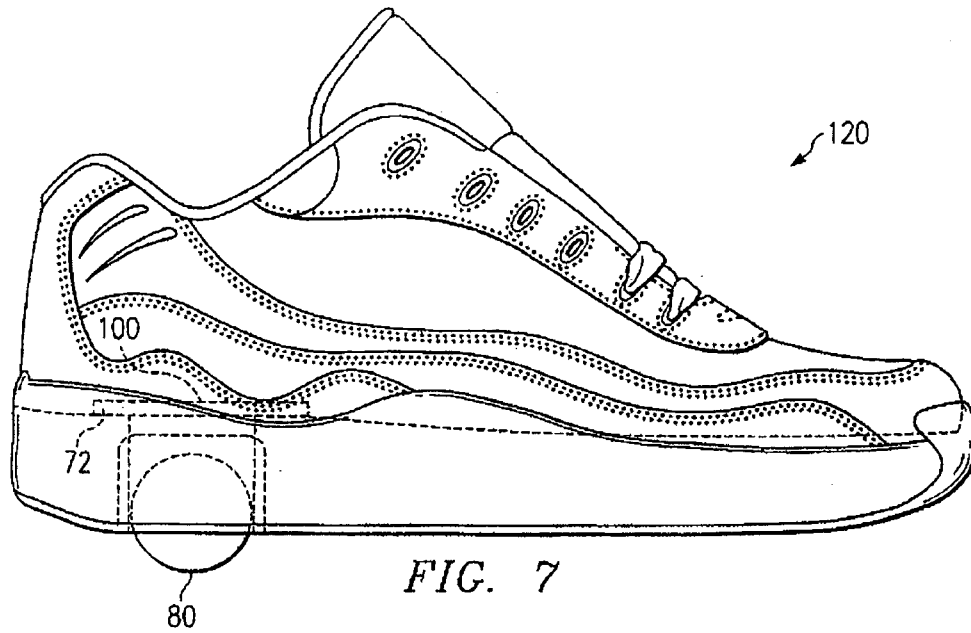

FIG. 8A

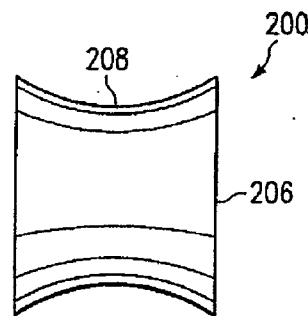

FIG. 8B

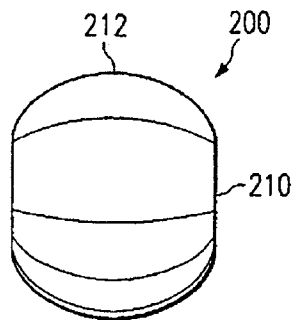

FIG. 8C

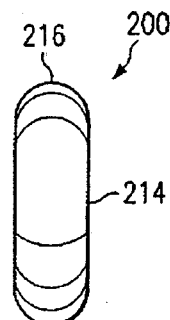

FIG. 8D

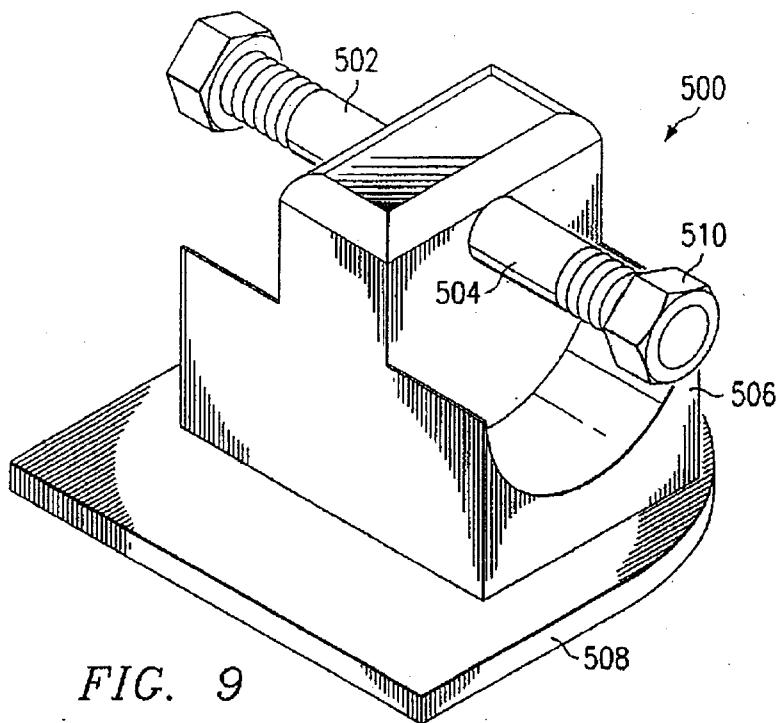

FIG. 9

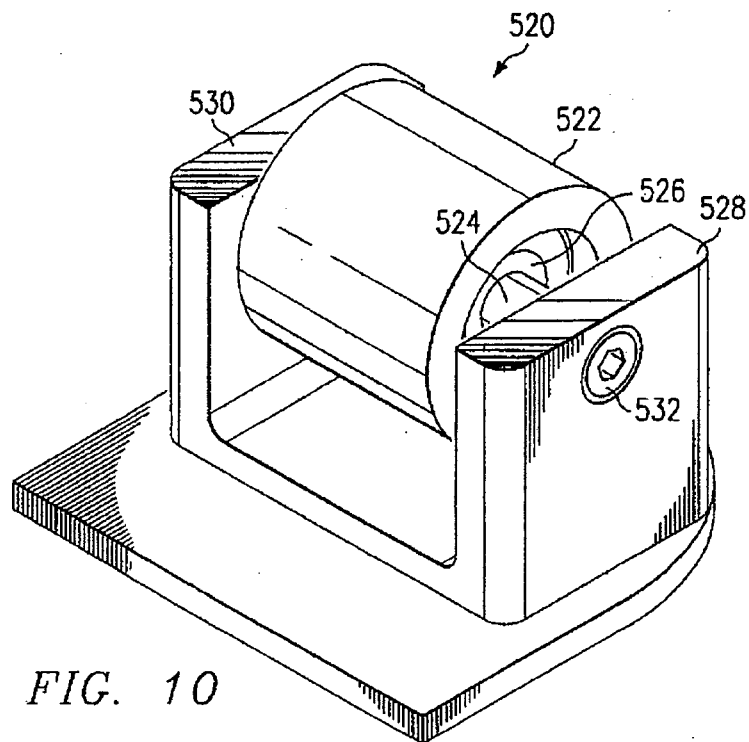

FIG. 10

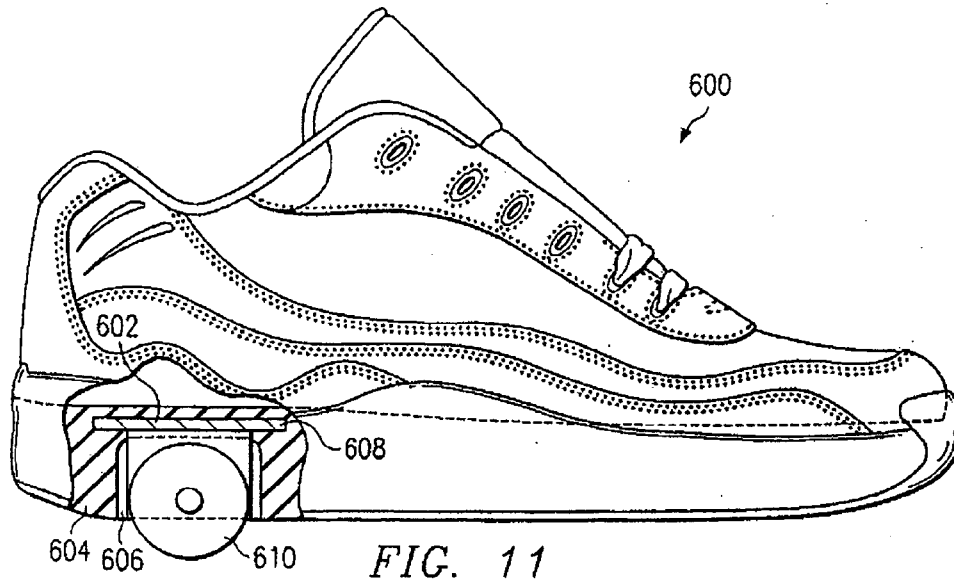

FIG. 11

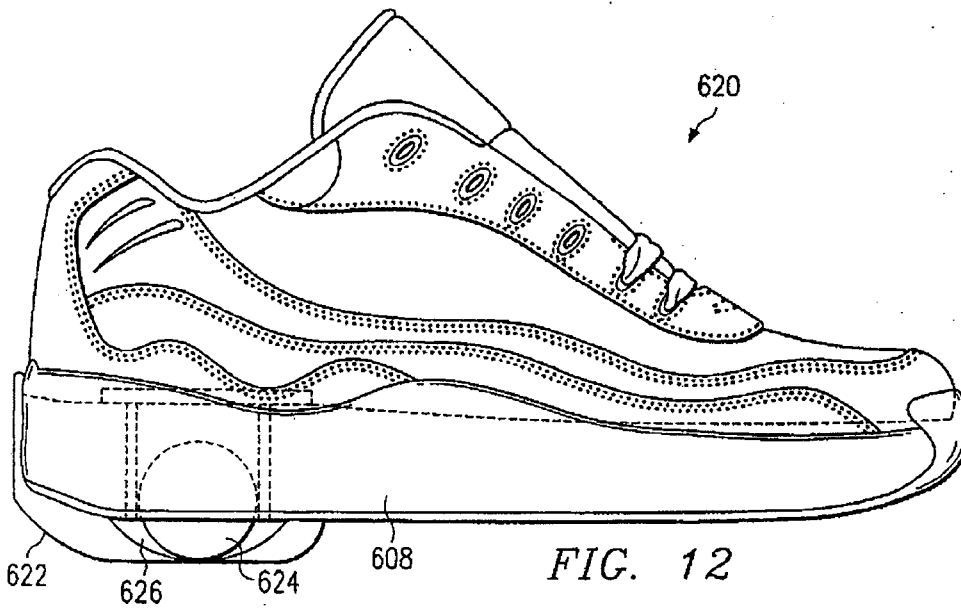

FIG. 12

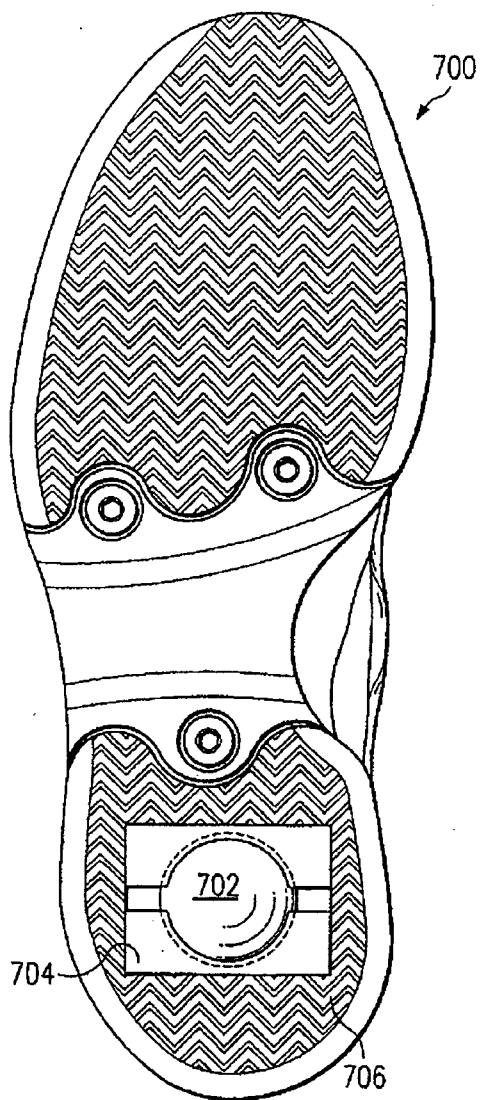

FIG. 13



FIG. 14

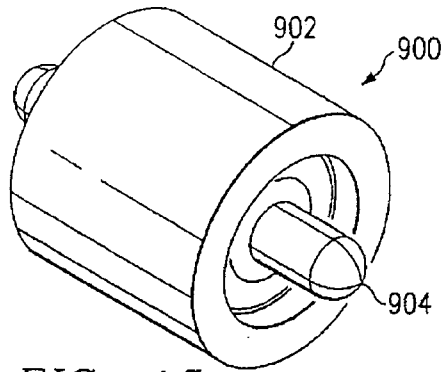

FIG. 15

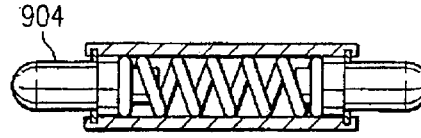

FIG. 16

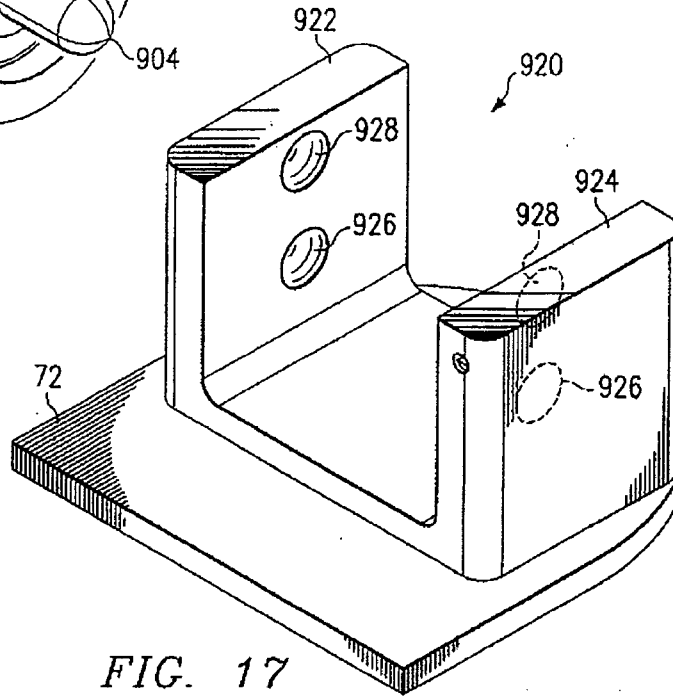

FIG. 17

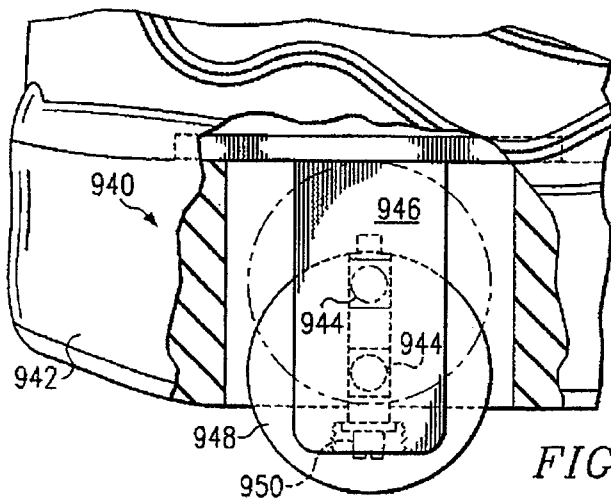

FIG. 18

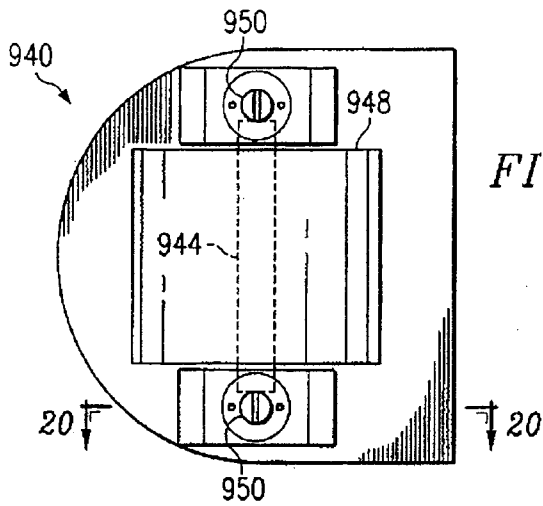

FIG. 19

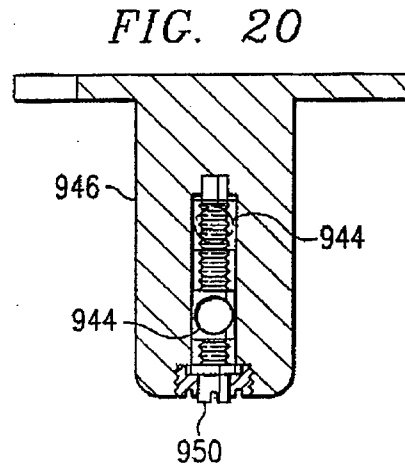

FIG. 20

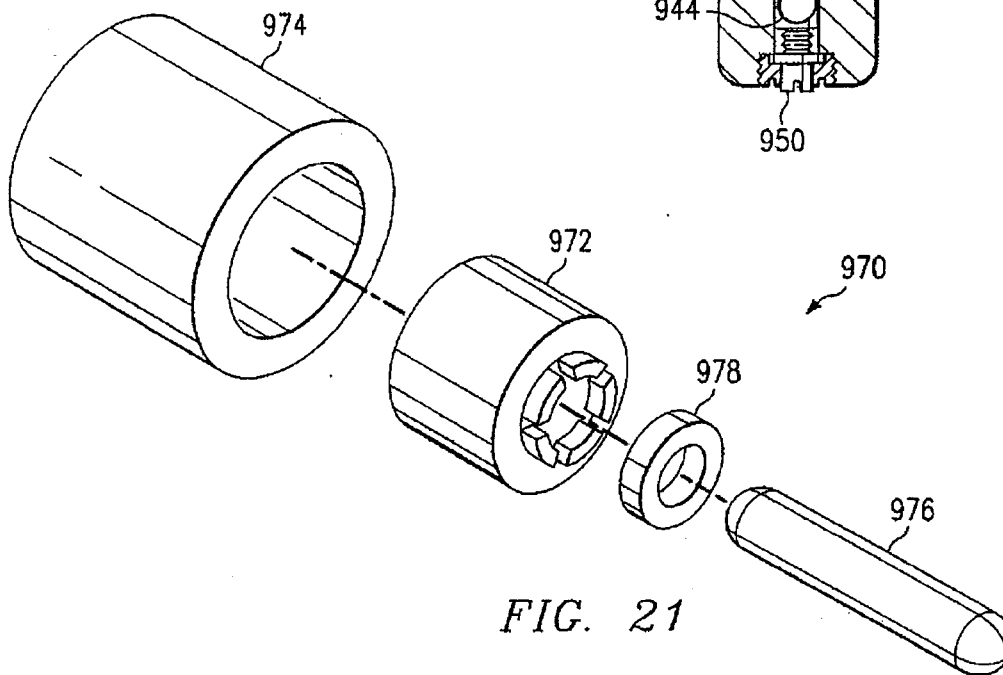

FIG. 21

## HEELING APPARATUS AND METHOD

## CROSS-REFERENCE TO RELATED APPLICATIONS

This application is a divisional application under 35 U.S.C. § 120 and claims priority from, and hereby incorporates by reference for all purposes, copending U.S. patent application Ser. No. 09/540,125, entitled *Heeling Apparatus and Method*, naming Roger R. Adams as inventor, filed Mar. 31, 2000, which, pursuant to 35 U.S.C. § 119(c), claims the benefit of U.S. Provisional Patent Application Ser. No. 60/127,459, entitled *Heeling Apparatus and Method*, naming Roger R. Adams as inventor, filed Apr. 1, 1999.

## TECHNICAL FIELD OF THE INVENTION

This invention relates in general to the field of footwear and active sports and more particularly to a heeling apparatus and method.

## BACKGROUND OF THE INVENTION

Action or extreme sports include various sports such as, for example, skateboarding, snow boarding, in-line skating, rock climbing, and skydiving. Most action or extreme sports require expensive and cumbersome equipment that can only be used in select and, often, limited areas. Because these select and limited areas are not convenient to most people, these activities can only be enjoyed at select times. This results in a substantial investment in equipment that is only used sporadically, when large blocks of time are available to travel to such select and limited areas available for the activity. Because of these limitations and inconveniences, many times interest in the activity wanes.

## SUMMARY OF THE INVENTION

The present invention presents the rare opportunity to create an entirely new sport and activity with mass appeal that does not suffer from the disadvantages, limitations, and problems mentioned above. From the foregoing it may be appreciated that a need has arisen for a heeling apparatus and related methods to create the foundation for a new action or extreme sport that can be pursued in many locations and conditions without the need for a large investment in equipment.

According to one aspect of the present invention, a heeling apparatus is provided that includes a footwear having an opening in a sole, such as the heel portion of the sole, to receive a wheel assembly, and a wheel assembly positioned in the opening of the sole of the footwear. The wheel assembly may include an axle, a wheel mounted on the axle, and a mounting structure operable to support the axle. In alternative embodiments, the wheel assembly includes only the wheel mounted on the axle without the need for the mounting structure. In other embodiments, the mounting structure is integrated or included as part of the opening in the sole of the footwear.

According to another aspect of the present invention a wheel/axle assembly for use in a wheel assembly of a heeling apparatus is provided that includes a wheel, a first bearing, a second bearing, and an axle. The wheel has an axle opening, a first annular recess on a first side of the wheel that surrounds the axle opening on the first side, and a second annular recess on a second side of the wheel that surrounds the axle opening on the second side. The first bearing is positioned in the first annular recess on the first side of the wheel, and the second bearing is positioned in the

second annular recess on the second side of the wheel. The axle is positioned within the axle opening of the wheel such that the wheel is rotatably coupled to the axle through the first bearing and the second bearing.

According to yet another aspect of the present invention, a method for using a heeling apparatus on a surface is provided that includes running on a surface by using a forefoot portion of a sole of the heeling apparatus to contact the surface, and rolling on the surface with a wheel of the heeling apparatus extended below the bottom of the sole through an opening in the sole by using a wheel of the heeling apparatus to contact the surface.

According to a still further aspect of the present invention, a method for making a heeling apparatus is provided that includes providing a footwear that includes a sole, forming an opening in the sole of the footwear that extends to a bottom surface of the sole, and positioning a wheel assembly in the opening of the sole of the footwear.

The present invention provides a profusion of technical advantages that include the capability of the heeling apparatus to function as normal, comfortable footwear for walking, and even running, and to function as rolling footwear, which may be referred to only herein as "heeling."

Another technical advantage of the present invention includes the capability to implement the invention using virtually any available footwear such as, for example, conventional shoes, boots, dress shoes, loafers, sandals, slippers, bindings, and the like. Conventional footwear may be incorporated into a heeling apparatus by, preferably, forming or cutting an opening in the heel portion of the sole of such conventional footwear. Thus, the present invention may be implemented using conventional footwear that appears externally, during normal use, as conventional footwear. This allows the present invention to be practiced as a "stealth" or "covert" activity because, from external appearances, it is being performed using conventional footwear. In a preferred embodiment of the present invention, the sole of conventional athletic shoes may be used in the present invention without the need to design awkward looking thick soled shoes to house the wheel.

A further technical advantage of the present invention includes the capability to implement the present invention with other active sport accessories such as in a grind shoe, such as the grind shoe made by SOAP, which also provides grinding or sliding functionality.

Yet another technical advantage includes the capability to use the present invention to enjoyably obtain an overall aerobic workout.

Still yet another technical advantage of the present invention includes the capability of enhanced control for turning and maneuvering, while still providing durability, reliability, and mechanical strength. The present invention provides this durability and reliability in harsh environments and with heavy and demanding use, including the capability to withstand the forces of jumps, spins and maneuvers of all kinds.

Another technical advantage includes capability of removable wheels and axles so that bearings may be easily changed and maintained and so that different types of wheels, bearings, and axles may be used as desired by the user and as dictated by the conditions.

In yet a further technical advantage of the present invention includes a wheel/axle assembly that can be easily inserted or removed from a wheel assembly or mounting structure, such as by using a friction fit. In other embodiments, the wheel assembly, or heeling apparatus, includes the capability of a retractable wheel. This allows a

user to quickly and conveniently convert from using the heeling apparatus as normal footwear into using the heeling apparatus for "heeling." The wheel is moved from a retracted position in the sole or heel of the heeling apparatus to an extended position where at least a portion of the wheel is exposed below the sole for rolling. The retractable wheel may be implemented using any number of designs and/or configurations such as a king pin arrangement, a dual position arrangement using a collapsible axle, a hinged arrangement, or even a spring arrangement.

Other technical advantages are readily apparent to one skilled in the art from the following figures, description, and claims.

#### BRIEF DESCRIPTION OF THE DRAWINGS

For a more complete understanding of the present invention and the advantages thereof, reference is now made to the following brief description, taken in connection with the accompanying drawings and detailed description, wherein like reference numerals represent like parts, in which:

FIG. 1 is a side view that illustrates a heeling apparatus implemented using an athletic shoe according to one embodiment of the present invention;

FIGS. 2A and 2B are bottom views that illustrate two embodiments of a sole of the heeling apparatus with openings in the sole;

FIGS. 3A and 3B are bottom views of the two embodiments of the sole as shown in FIGS. 2A and 2B and illustrate a wheel in each of the openings of the soles;

FIG. 4 is a perspective view that illustrates a wheel rotatably mounted to an axle, which also may be referred to as a wheel/axle assembly, for use in a wheel assembly according to one embodiment of the present invention;

FIG. 5 is a perspective view that illustrates a mounting structure for use with a wheel rotatably mounted to an axle, as illustrated in FIG. 4, to form a wheel assembly;

FIG. 6 is a bottom view that illustrates a wheel assembly that includes the wheel rotatably mounted on the axle as shown in FIG. 4 and the mounting structure of FIG. 5;

FIG. 7 is a side view that illustrates the wheel assembly positioned above and through the opening in a footwear to form a heeling apparatus;

FIGS. 8A, 8B, 8C, and 8D are profile views of various wheels that illustrate the surface profile of these wheels that may be used in various embodiments of the present invention;

FIG. 9 is a perspective view that illustrates a mounting structure of another embodiment for use in a wheel assembly of a heeling apparatus;

FIG. 10 is a perspective view that illustrates a wheel-assembly that uses yet another embodiment for use in a heeling apparatus;

FIG. 11 is a side, partial cutaway view that illustrates one embodiment of a heeling apparatus that illustrates the wheel assembly provided in the sole of the heeling apparatus and the opening in the sole not extending completely through the sole;

FIG. 12 is a side view of another embodiment that illustrates the heeling apparatus of the present invention with a removable wheel cover positioned to cover the wheel and the opening in the sole;

FIG. 13 is a bottom view that illustrates another embodiment of the present invention with a spherical ball serving as a wheel and positioned in a mounting structure in an opening in the heel portion of the sole;

FIG. 14 is a perspective view that illustrates a "heeler" using the present invention to "heel";

FIG. 15 is a perspective view that illustrates a wheel rotatably mounted to an axle, which also may be referred to as a wheel/axle assembly, similar to FIG. 4;

FIG. 16 is a cutaway view that illustrates a collapsible axle of the wheel/axle assembly of FIG. 15 implemented as a spring loaded collapsible axle;

FIG. 17 is a perspective view that illustrates another mounting structure for use with the wheel/axle assembly and the collapsible axle, as illustrated in FIG. 15 and FIG. 16, to form a wheel assembly;

FIG. 18 is a side, cutaway view that illustrates a wheel assembly positioned through an opening in a sole that illustrates one embodiment of an axle that couples to the mounting structure to provide a retractable wheel using an assembly that may be referred to as a king pin arrangement;

FIG. 19 is a bottom view that illustrates the wheel assembly of FIG. 18 that further illustrates the dual king pin arrangement;

FIG. 20 is a side view that illustrates one member of the mounting structure that further illustrates the coupling of the axle to the mounting structure using the dual king pin arrangement; and

FIG. 21 is a breakaway and perspective view that illustrates a two piece wheel that includes an inner core and an outer tire and that may be used in the present invention.

#### DETAILED DESCRIPTION OF THE INVENTION

It should be understood at the outset that although an exemplary implementation of the present invention is illustrated below, the present invention may be implemented using any number of techniques, materials, designs, and configurations whether currently known or in existence. The present invention should in no way be limited to the exemplary implementations, drawings, and techniques illustrated below, including the exemplary designs and implementations illustrated and described herein.

It should be understood at the outset that although exemplary implementations of the present invention are illustrated below, the present invention may be implemented using any number of mechanisms, arrangements, structures, and/or techniques. Thus, the present invention should in no way be construed to be limited to the exemplary implementations, drawings, and techniques illustrated and described herein.

FIG. 1 is a side view of a heeling apparatus 10 implemented using an athletic shoe 12 according to one embodiment of the present invention. The heeling apparatus 10 preferably includes a wheel assembly provided in an opening in the heel portion of the sole of a footwear. For example the athletic shoe 12 includes an opening in the bottom of a heel portion 18 of a sole 14 with a wheel assembly provided in the hole such that a wheel 16 extends below the bottom of the sole 14. The wheel assembly preferably includes at least one wheel, such as the wheel 16, rotatably mounted on an axle (not illustrated in FIG. 1). The wheel 16 mounted on the axle is preferably positioned in the opening of the sole 14 through a mounting structure (not illustrated in FIG. 1) that is operable to support the axle such that a portion of the wheel 16 extends below the heel portion 18 of the sole 14.

The amount or length of the portion of the wheel 16 that extends below the bottom of the sole 14, as defined by a distance 24, will preferably be less than the diameter of the

wheel 16. The distance 24, however, may be greater than, less than, or equal to the diameter of the wheel 16.

The athletic shoe 12, as is true of most footwear, may be generally described as having the sole 14 and an upper part 26. The upper part 26 may be constructed of virtually any material such as, for example, leather, plastic, or canvas. The sole 14 may include three parts: (1) an inner sole or insole (not illustrated in FIG. 1); (2) a midsole 28; and (3) an outer sole or outsole 30. The insole may provide added cushion and may or may not be removable. In some embodiments, the insole may include a removable portion, such as a DR. SCHOLL'S insole, and a portion that remains attached to the athletic shoe 12. The outsole 30 will preferably be made of a durable material, such as rubber, and may have a textured surface, such as with knobs, to provide added traction. The midsole 28 will generally be constructed of a soft or "cushiony" material and will generally be thicker than the insole and the outsole 30. In some embodiments, however, the sole 14 will comprise only one part, such as the leather sole of a loafer. In other embodiments, the sole 14 may include a separate heel block or object that elevates the footwear, such as the heel of a leather wingtip dress shoe. This heel block or object may be considered to be part of the heel portion 18 of the sole 14. It should be understood that the present invention may be implemented in virtually any footwear, irrespective of the design or the make-up of the sole 14. Various styles of footwear and methods of making footwear are known in the art and are known by one of ordinary skill in the art. For example, U.S. Pat. Nos. 4,245,406, 5,319,869, 5,384,973, 5,396,675, 5,572,804, 5,595,004, and 5,885,500, which are hereby incorporated by reference for all purposes, provide various background information regarding various footwear and methods of making footwear.

In most footwear, including the athletic shoe 12, the sole 14 may also be divided into three portions or regions: (1) the heel portion 18, (2) an arch portion 20, and (3) a forefoot portion 22, as illustrated in FIG. 1. It should be understood that the heel portion 18, the arch portion 20, and the forefoot portion 22 of the sole 14 are incapable of being exactly defined and located, and that such portions vary from one footwear type to another. Thus, the location, the boundaries between, and the size of the heel portion 18, the arch portion 20, and the forefoot portion 22 of the sole 14 are only rough approximations.

It should also be understood that although the position of the opening in the bottom of the sole 14, and hence also the wheel 16, is preferably located in the heel portion 18 of the sole 14, such an opening may also be located at the boundary of the heel portion 18 and the arch portion 20, at the arch portion 20, or at virtually any other location on the sole 14. The opening in the bottom of the sole 14 may extend entirely through the sole 14, e.g., through the outsole, the midsole and the insole, or only partially through the sole 14, e.g., through the outsole, and a portion or all of the midsole.

The wheel 16 may be constructed or made of virtually any known or available material such as, for example, a urethane, a plastic, a polymer, a metal, an alloy, a wood, a rubber, a composite material, and the like. This may include, for example, aluminum, titanium, steel, and a resin. Preferably, the material will be durable, provide quiet performance, and will provide a "soft" or "cushioning" feel. In one embodiment, the wheel 16 may be implemented as one or more precision bearings such that the precision bearing serves as the wheel 16 itself. In yet another embodiment, the wheel assembly may include a spring or suspension such as, for example, a leaf spring, to provide

additional cushion or suspension when the wheel 16 contacts a surface and a force is applied to the athletic shoe 12 in the direction of the surface, such as when a someone is wearing and walking in the heeling apparatus 10. The spring is preferably provided as part of the mounting structure of the wheel assembly. In still another embodiment, the wheel 16 is provided as a two piece wheel with an inner core, such as a hard inner core, surrounded by an outer tire, such as a urethane tire.

Depending on the desired implementation, the wheel 16 and the axle may be removable from the wheel assembly. In such a case, a removable cover may be provided in the opening in the sole 14 to cover the opening so that debris and dirt does not enter the opening. The removable cover may be provided in virtually any available configuration readily ascertainable by one of ordinary skill in the art. In one embodiment of the removable cover, an axle portion of the removable cover fits and/or couples to the mounting structure in the same or similar manner that the axle in which the wheel 16 is mounted fits and/or couples to the mounting structure of the wheel assembly. A tool may also be provided to facilitate the removal of the axle and wheel 16. This tool will, preferably, be small and multi-functional to provide any other possible adjustments to the heeling apparatus 10, such as a screw driver, a wrench, and the like. In other embodiments of the heeling apparatus 10, the wheel 16 may be retractable into the opening in the sole 14. In this manner, the wheel 16 may be retracted into the sole 14 and, thus, will not extend below the bottom of the sole 14. This allows the heeling apparatus 10 to function just like ordinary footwear, such as the athletic shoe 12.

In one embodiment of the present invention, the wheel assembly does not include an axle, and, arguably, not a mounting structure, and the wheel 16 is provided as a sphere, such as a stainless steel ball bearing, that is rotatably positioned in the opening in the bottom of the heel portion 18 of the sole 14, one embodiment of which is shown in FIG. 13. In another embodiment, the wheel assembly comprises an axle positioned completely through or partially through the heel portion 18 of the sole 14 such that the sole 14 supports the axle and the wheel is rotatably mounted on the axle in the opening of the sole 14. In this manner, the need for the mounting structure is eliminated.

In operation, a person wearing the heeling apparatus 10 may either walk normally or roll on the wheel 16 by lifting or raising the sole 14 so that only or almost only the wheel 16 contacts a surface. This action may be referred to as "HEELING" or to "HEEL." The wheel 16, depending on the desired implementation of the present invention, may be removed or retracted to a position such that the wheel 16 does not extend below the bottom of the sole 14. This, generally, will result in the heeling apparatus 10 performing like an associated footwear. When the wheel 16 is removed or retracted, a removable cover may be placed over the opening in the bottom of the sole 14 to prevent debris from entering the opening and potentially damaging the wheel assembly. In still other embodiments, a removable cover may be placed over the wheel 16 while a portion of the wheel 16 remains extended below the bottom of the sole 14 to assist with walking, an example of this is illustrated in FIG. 12.

It should be understood, however, that even if the wheel 16 is not removed or retracted as just described, the user may still comfortably walk and run, even with the wheel 16 extended. This generally occurs because the distance 24 can be minimal, which provides a unique "stealth" or "covert" aspect to heeling. This also results in the wheel rolling the

opening or hole in the sole 14 of the heeling apparatus 10. In one embodiment, the distance 24 is less than the radius of the wheel 16, which results in most of the wheel residing within the opening of the sole 14.

FIGS. 2A and 2B are bottom views of two embodiments of the sole 14 of the heeling apparatus 10. In particular, the outsole 30 or bottom of the sole 14 is illustrated in FIG. 2A with an opening 40 in the heel portion 18 of the sole 14. In the embodiment illustrated, the opening 40 is provided in a square or rectangular configuration. The opening 40, however, may be provided in virtually any configuration, such as, for example, a circular or an elliptical configuration.

As mentioned previously, the opening 40 may extend partially or completely through the sole 14. The opening 40 may be provided through a heel block or object. Further, the opening 40 be positioned in, near, or in a combination of the heel portion 18, the arch portion 20, and the forefoot portion 22.

FIG. 2B illustrates a second embodiment as to the placement and configuration of the opening 40. The outsole 30 is illustrated with an opening 40A and an opening 40B in the heel portion 18 of the sole 14. In this manner, one or more wheels, including one or more axles, may be positioned in both the opening 40A and 40B.

FIGS. 3A and 3B are bottom views of the two embodiments of the sole 14 as shown in FIGS. 2A and 2B and illustrate a wheel in each of the openings of the soles. This includes a wheel 42 positioned in the opening 40 in FIG. 3A and a wheel 42A and a wheel 42B in the openings 40A and 40B, respectively, of FIG. 3B.

The wheel 42 and the wheels 42A and 42B are illustrated as cylindrical wheels. These wheels, however, may be provided in virtually any available configuration. Further, one or more wheels may be positioned in each opening.

FIG. 3A further illustrates other elements of the wheel assembly that include a first member 48 and a second member 54 of a mounting structure that is used to removably couple with an axle 50. The axle 50 extends through the wheel 42 such that the wheel 42 is rotatably coupled or mounted to the axle 50. This preferably involves the use of precision bearings, such as high performance precision bearings, provided in a recess, such as an annular recess, on either side of the wheel 42. A first precision bearing 56 and a second precision bearing 58 may be ABEC grade precision bearings and are illustrated with hidden lines and positioned in the first recess and second recess of the wheel 42. In alternative embodiment, loose ball bearings may be used.

The axle 50 may be made of any material that provides suitable physical characteristics, such as strength and weight, to name a few. The axle 50 is preferably made of hardened steel, is cylindrical in shape, each end is rounded, and is removably coupled with a first member 48 and a second member 54, respectively, of the mounting structure. The removable coupling between each end of the axle 50 and the first member 48 and the second member 54 may be achieved by any known or available mechanism. In a preferred embodiment, a sphere or a ball bearing, preferably using a moveable spring and/or a screw bias, is used to contact and exert a side wall force between one or members of the mounting structure and the axle 50.

It should also be noted that because the weight of the user of the heeling apparatus 10 will exert a significant downward force and the ground or surface will exert an equal force upward, the axle 50, and, hence, the wheel 42 will generally be forced into place. Only when the heel is raised from a surface will any force or friction be required to keep

the axle 50 in place. Thus, the present invention does not require a large side force to keep the axle 50 and the wheel 42 in place. The recognition of this fact may be considered an aspect of the present invention for the embodiment as shown. This recognition allows the removable coupling between each end of the axle 50 and the first member 48 and the second member 54 to be optimally designed.

FIG. 3A also illustrates a grind plate 44 (which also may be referred to as a slide plate 44) that may be used in conjunction with the heeling apparatus 10 of the present invention. The grind plate 44 provides a smooth or relatively smooth surface to allow a user to "grind" or "slide" on various surfaces such as hand rails, curbs, steps, corners, and the like. The grind plate 44 is preferably somewhat thin and made of a plastic or polymer material. In a preferred embodiment, the grind plate 44 is removably attached to the arch portion 20 of the outsole 30 of the sole 14. The grind plate 44 may be attached using any known or available fastener, such as, for example, a fastener 46 shown in various locations around the periphery of the grind plate 44.

FIG. 3B further illustrates an axle 52 in which the wheel 42A and the wheel 42B are coupled to either end in the opening 40A and the opening 40B, respectively. The axle 52 extends through both the wheels 42A and 42B and through a portion of sole 14, not visible in FIG. 3B. This serves to support the axle 52 and illustrates the situation where the sole 14 serves as the mounting structure of the wheel assembly. This reduces the overall number of parts. In an alternative embodiment, a metal or some other suitable material may be used within the heel portion 18 of the sole 14 where the axle 52 is positioned to provide additional support and stability. This is an example where the mounting structure is, in effect, integrated into the sole 14. As can be appreciated by one skilled in the art, the present invention may be implemented in any number of ways.

FIG. 4 is a perspective view of a wheel 60 rotatably mounted on an axle 62, which also may be referred to as a wheel/axle assembly, for use in a wheel assembly, or in a heeling apparatus, according to one embodiment of the present invention. The wheel 60 and the axle 62 may also be referred to as a wheel/axle assembly 400. In this embodiment, the axle 62 extends through the wheel 60 and includes two ends that are rounded or bullet shaped. A precision bearing 64 is shown positioned in a recess, which is shown as an annular recess, of the wheel 60 to facilitate the rotation of the wheel 60 around the axle 62. Preferably a second precision bearing is positioned in a second recess, not shown in FIG. 4, to further facilitate such rotation.

A slip clip, slip ring, or ring clip 66 is shown positioned around, or nearly around, the axle 62 near the precision bearing 64. This serves to ensure that the precision bearing 64 remains in place in the recess of the wheel 60. The slip clip or ring clip 66 will preferably be positioned on the axle 62 through a groove, such as a radial groove or radial indentation, in the axle 62. It should be understood, however, that one of ordinary skill in the art may use any of a variety of other arrangements to ensure that the precision bearing 64 stays in position. In alternative embodiments, the precision bearing 64 may be eliminated or loose bearings may be used.

The wheel 60 rotatably mounted on the axle 62 may, in alternative embodiments, serve as the wheel assembly of the present invention. In such a case, the axle 62 may be mounted to the sole, such as the midsole and heel portion, at its ends while the wheel 60 is rotatably provided in the opening of the sole. In this manner, the need for a mounting

structure may be thought of as eliminated or, alternatively, the mounting structure may be thought of as integrated into the sole of the footwear.

FIG. 5 is a perspective view of a mounting structure 70 for use with a wheel rotatably mounted to an axle, such as is illustrated in FIG. 4, to form a wheel assembly. The mounting structure 70 generally includes a heel control plate 72, a first member 74, and a second member 76. In alternative embodiments, a spring, such as a leaf spring, could be provided where the two members contact the heel control plate 72. This would provide the added benefit of greater cushion and suspension. The two members include an opening, such as the opening 78 of the first member 74 to receive an end of an axle. It should be mentioned that the opening may be provided in virtually any configuration, including extending through the member, or placed at different positions, or even multiple positions for mounting the wheel/axle assembly 400 at a retractable position and an extended position, on the member.

The axle that is to be positioned in the openings of the first member 74 and the second member 76 will preferably be removably coupled. This may be achieved by any number of arrangements and configurations, all of which fall within the scope of the present invention. One such arrangement is the screw/spring/ball bearing arrangement 80 provided in first member 74. This arrangement provides an adjustable bias or force that can be exerted against the axle when it is inserted into the opening 78. The screw is accessible and adjustable by the user. The turning of the screw affects the compression of a spring which, in turn, provides a force on a ball bearing that extends out into the opening 78. When the axle is inserted into the opening 78, the ball bearing may be displaced an amount and the screw/spring/ball bearing arrangement 80 will provide a side force to allow the axle to be secure, yet removable. A similar arrangement may also be provided in the second member 76 to provide a friction fit or coupling on the other end of the axle 62.

Although the screw/spring/ball bearing arrangement 80 of FIG. 5 is shown being implemented through a horizontal opening in the first member 74, it may be implemented in using an opening aligned in virtually in manner in the member. For example, the adjustment of the tension or pressure on the screw/spring/ball arrangement 80 may be achieved through a diagonal opening such that the exposed end of the screw/spring/ball arrangement 80, normally a screw head end, is provided where the reference line for numeral 74 in FIG. 5 contacts the first member 74. This provides easier access to adjust the tension and friction fit on the axle 62 when the wheel assembly, such as wheel assembly 100 of FIG. 6, is engaged or positioned within the opening of a sole to form a heeling apparatus. Of course, any of a variety of other arrangements, configurations, and opening alignments may be contemplated and implemented under the present invention.

The mounting structure 70 can be made or constructed of virtually any material, generally depending on the desired mechanical characteristics such as, for example, rigidity and strength. These materials may include, for example, a plastic, a polymer, a metal, an alloy, a wood, a rubber, a composite material, and the like. This may include aluminum, titanium, steel, and a resin. In one embodiment, the mounting structure 70 is made of a metal, such as aluminum, that has been anodized such that the mounting structure 70 presents a black color or hue.

FIG. 6 is a bottom view of a wheel assembly 100 that includes the wheel 60 rotatably mounted to the axle 62, as

shown in FIG. 4, and the mounting structure 70 of FIG. 5. The first member 74 and the second member 76 each removably couple with the ends of the axle 62 through a bias mechanism implemented using a bias mechanism, such as the screw/spring/ball bearing arrangement 80. A ball bearing 102 is shown contacting one end of the axle 62 in the opening 78. Further slip clips or ring clips (which may also be referred to as snap rings or slip rings), such as ring clip 66, are provided to ensure that the precision bearings positioned in the recesses of the wheel remain in position.

The heel control plate 72 allows the user of the heeling apparatus to gain greater control and to obtain greater performance out of the heeling apparatus.

FIG. 7 is a side view of the wheel assembly 100 positioned above and through the opening to form a heeling apparatus 120. The heel control plate 72 resides inside the shoe so that the heel of the user may apply pressure to the heel control plate as desired to provide better handling and performance of the heeling apparatus 120.

FIGS. 8A, 8B, 8C, and 8D are profile views of various wheels 200 that illustrates the surface profile of these wheels that may used in various embodiments of the present invention. In FIG. 8A, a wheel 202 is shown with a flat or square surface or exterior profile 204. In FIG. 8B, a wheel 206 is shown with an inverted surface profile 208. In FIG. 8c, a wheel 210 is shown with round surface profile 212. Finally, in FIG. 8D, a wheel 214 is shown with a steep surface profile 216. The present invention may incorporate virtually any available surface profile of a wheel.

FIG. 9 is a perspective view that illustrates a mounting structure 500 of another embodiment for use in a wheel assembly of a heeling apparatus. The mounting structure 500 includes an axle 502, which may be considered one axle that extends through and is mounted through a member 50 or as an axle 502 that couples with the member 506 along with an axle 504 that couples with the member 506 opposite axle 502. The mounting structure 500 also includes a heel control plate 508 coupled with the member 506.

The mounting structure 500 allows for two wheels to be mounted to form a wheel assembly. A wheel may be rotatably mounted on the axle 502, preferably using a precision bearing, and a wheel may be rotatably mounted on the axle 504, also preferably through a precision bearing as illustrated previously herein.

The axle 502 and the axle 504 include a threaded portion such that a nut, such as a lock nut 510 may be included to secure a wheel to each axle. In other embodiments, the end of the axles may include internal threads, as opposed to external threads as shown, so that a screw, such as the hex screw as shown in FIG. 10. It should be understood that virtually any available coupling may be provided between the axle and the member.

FIG. 10 is a perspective view that illustrates a wheel assembly 520 that uses yet another embodiment for use in a heeling apparatus and includes a wheel 522 rotatably mounted to an axle 524 using a precision bearing 526, and a first member 528 and a second member 530 coupled to each end of the axle 524 through a screw, such as hex screw 532. The wheel assembly 520 is similar to wheel assembly 100, which was described above in connection with FIG. 6, except that the wheel/axle assembly cannot be as easily inserted and removed.

FIG. 11 is a side, partial cutaway view that illustrates one embodiment of a heeling apparatus 600 that illustrates a wheel assembly 602 provided in a sole 604 and an opening 606 in the sole 604 that does not extend completely through

the sole 604. As such, the mounting structure 608 may be provided or integrated into the sole 604 and may not be readily or easily removed. A wheel 610 is also shown extending partially below the bottom of the sole 604, which provides the advantage of stealth heeling.

FIG. 12 is a side view of another embodiment that illustrates a heeling apparatus 620 of the present invention with a removable wheel cover 622 positioned to cover a wheel 624 and an opening 626 in a sole 628. The removable wheel cover 622 allows for the wheel to be provided in an extended position, i.e., below the bottom surface of the sole 628, yet not engage a surface to roll. Although the heeling apparatus 620 of the present invention allows a user to walk and run, even with the wheel in an engaged position, the removable wheel cover 622 provides protection from dirt and debris and provides greater stability.

In an alternative embodiment, a wheel stop, not expressly shown in FIG. 12, may be provided, in lieu of or in conjunction with the removable wheel cover 622, to stop the rotation of the wheel 624. In one embodiment, the wheel stop is made of virtually any material, such as a sponge or flexible material, that can be wedged between the wheel 624 and the opening 626 to stop or prevent the rotation of the wheel 624 and to stay in place through friction.

In other embodiments of the wheel cover 622, a wheel cover is provided when the wheel 624 has been removed from the heeling apparatus 620. In a preferred embodiment, this wheel cover is generally flush with the remainder of the bottom of the sole 608, and, hence, provides the function of a regular shoe when desired and protects the opening. This wheel cover may couple in any available manner, but preferably will couple to the wheel assembly in the same or similar manner that the wheel/axle assembly couples to the mounting structure. The removable wheel cover could clip or attach to the wheel assembly in many different ways.

FIG. 13 is a bottom view that illustrates another embodiment of a heeling apparatus 700 with a spherical ball 702 serving as a wheel and positioned in a mounting structure 704 in an opening in the heel portion of the sole 706.

FIG. 14 is a perspective view that illustrates a "heeler" 800 using the present invention to "heel." Heeling can be achieved using various techniques and, generally, requires a skill set of balance, positioning, flexibility, and coordination.

An illustrative method for using a heeling apparatus on a surface may include running on a surface by using a forefoot portion of a sole of the heeling apparatus to contact the surface, and then rolling on the surface with a wheel of the heeling apparatus extended below the bottom of the sole through an opening in the sole by using a wheel of the heeling apparatus to contact the surface. Before running on a surface, the method may include walking on the surface while wearing the heeling apparatus with a wheel of the heeling apparatus extended below the bottom of a sole portion of the heeling apparatus before running on the surface. Heeling may also be performed on a hill or a surface that includes a decline.

The method of heeling may also include engaging the wheel of the heeling apparatus to extend below the bottom of the sole portion of the heeling apparatus before walking on the surface. The method may also include walking on the surface while wearing the heeling apparatus before engaging the wheel of the heeling apparatus and with the wheel of the heeling apparatus retracted. Other variations on the method may include transitioning from rolling on the surface to either running, walking, or stopping on the surface by running on the surface through using the forefoot portion of

the sole of the heeling apparatus to contact the surface just after rolling on the surface.

The preferred position while heeling is illustrated by the heeler 800 in FIG. 14 where one heeling apparatus 802 is placed in front of the other heeling apparatus 804 while rolling on a surface. As can be seen from a back heel portion 806 of the heeling apparatus 804, sometimes the clearance between the back heel portion 806 and the surface is small. As a result, in a preferred embodiment, the back heel portion 806 is made of a wear resistant material.

The method of heeling may also implement any number of techniques for slowing or stopping. For example, rolling may be slowed by contacting the forefoot portion of the sole of the heeling apparatus to contact the surface to create friction and to remove the wheel from the surface. Another example includes slowing by contacting a heel portion of the sole of the heeling apparatus to contact the surface.

FIG. 15 is a perspective view that illustrates a wheel 902 rotatably mounted to a collapsible axle 904, which also may be referred to as a wheel/axle assembly 900, similar to FIG. 4. The collapsible axle 904 may be implemented in any number of ways, such as an adjustable axle that is spring loaded, similar to what is shown in FIG. 16, or as a screw collapsible axle. This allows the wheel/axle assembly 900 to be more easily removable and/or retractable to a position where the wheel would not engage the ground if the wheel/axle assembly 900 were implemented in a heeling apparatus.

FIG. 16 is a cutaway view that illustrates a collapsible axle 904 of the wheel/axle assembly 900 of FIG. 15 implemented as a spring loaded collapsible axle. As can be seen, the collapsible axle 904 may be adjusted or shortened by inwardly compressing both ends of the collapsible axle 904 to overcome the internal spring force.

FIG. 17 is a perspective view that illustrates another mounting structure 920 for use with the wheel/axle assembly 900 and the collapsible axle 904, as illustrated in FIG. 15 and FIG. 16, respectively, to form a wheel assembly. The collapsible axle 904 may couple to a first member 922 and a second member 924 at a first position 926 at the first member 922 and the second member 924 so that the wheel is in a retracted position. The collapsible axle 904 may also couple to the first member 922 and the second member 924 at a second position 928 so that the wheel is in an extended position.

FIG. 18 is a side, cutaway view that illustrates a wheel assembly 940 positioned through an opening in a sole 942 that illustrates one embodiment of an axle 944 that couples to a mounting structure 946 to provide a retractable wheel 948 using an assembly that may be referred to as a king pin arrangement or dual king pin arrangement. This allows the retractable wheel 948 to be adjusted up or down, as desired, and from a retractable position to an extended position. A king pin 950 (which may be implemented as a threaded screw or bolt) is shown threadingly engaged in a threaded opening in a member of the mounting structure 946. As the king pin 950 is screwed further into the opening in the member, the axle 944 is further retracted. A king pin 950 will also be provided at the other member to raise the other side of the axle 944.

In other embodiments, such as the mounting structure 500 in FIG. 9, a single king pin could be provided through the single member to provide retractable wheels through the coupling of the members and the axle.

An example of a king pin type assembly is illustrated in U.S. Pat. No. 4,295,655, which is incorporated herein by

reference for all purposes, issued to David L. Landay, et al., was filed on Jul. 18, 1979, was issued Oct. 20, 1981. This patent illustrates a king pin type assembly that could be implemented in an embodiment of the present invention.

FIG. 19 is a bottom view that illustrates the wheel assembly 940 of FIG. 18 and further illustrates the dual king pin arrangement and the king pins 950 through the members of the mounting structure 946.

FIG. 20 is a side view that illustrates one member of the mounting structure 946 and further illustrates the coupling of the axle 944 to the mounting structure 946 using the dual king pin arrangement similar to FIG. 18. As discussed above, this allows the axle 944, and hence the attached wheel, to be transitioned to any of a desired levels, and from a retracted position to an extended position.

It should be understood that the axle may couple to a member of a mounting structure using any available technique and in virtually an unlimited number of ways. For example, an axle may couple to the first member and the second member of a mounting structure to move from a retracted position to an extended position through a spring arrangement. Similarly, an axle may couple to the first member and the second member of a mounting structure to move from a retracted position to an extended position through a hinged arrangement.

Many other examples are possible, for example U.S. Pat. No. 3,983,643, which is incorporated herein by reference for all purposes, issued to Walter Schreyer, et al., was filed on May 23, 1975, was issued Oct. 5, 1976 illustrates a retractable mechanism that may implemented in one embodiment of the present invention. U.S. Pat. No. 5,785,327, which is incorporated herein by reference for all purposes, issued to Raymond J. Gallant, was filed on Jun. 20, 1997, issued on Jul. 28, 1998 illustrates simultaneously retractable wheels.

FIG. 21 is a breakaway and perspective view that illustrates a two piece wheel 970 that includes an inner core 972, an outer tire 974, such as a urethane wheel, an axle 976 (which may not be shown to skill), and a bearing 978 that may be used in the present invention. In a preferred embodiment, the bearing 978 is small in comparison to the two piece wheel 970, for example, the bearing 978 may have an outer diameter that is less than half the outer diameter of the outer tire 974. This can provide significant advantages, that include a softer ride, better control, and are longer lasting. This is because the outer tire 974 can be larger and thicker. In other embodiments, the bearing 978 is larger and has an outer diameter that is more than half the outer diameter of the outer tire 974. In a preferred embodiment, the inner core portion of the two piece wheel is made of a harder material that provides rigidity for enhanced bearing support, while the outer tire portion is made of a softer material, such as a soft urethane, for improved performance and a quieter ride. These types of wheels may be referred to as a "dual durometer" type wheel.

Thus, it is apparent that there has been provided, in accordance with the present invention, a heeling apparatus and method that defines a new activity and sport that satisfies one or more of the advantages set forth above. Although the preferred embodiment has been described in detail, it should be understood that various changes, substitutions, and alterations can be made herein without departing from the scope of the present invention, even if all of the advantages identified above are not present. For example, the various embodiments shown in the drawings herein illustrate that the present invention may be implemented and embodied in a variety of different ways that still fall within the scope of the

present invention. Also, the techniques, designs, elements, and methods described and illustrated in the preferred embodiment as discrete or separate may be combined or integrated with other techniques, designs, elements, or methods without departing from the scope of the present invention. For example, the wheel assembly may be removable or integrated into the sole of the footwear. Although the present invention has been primarily described with only one wheel positioned in the opening of the heel, the present invention certainly contemplates and covers multiple wheels positioned in the opening of the heel. Other examples of changes, substitutions, and alterations are readily ascertainable by one skilled in the art and could be made without departing from the spirit and scope of the present invention.

What is claimed is:

1. A method for use of a heeling apparatus on a surface by a user, the method comprising:

moving on a surface in a first direction by placing at least a portion of a forefoot of the heeling apparatus in contact with the surface;

rolling on the surface in generally the first direction while the forefoot of the heeling apparatus is elevated relative to the surface such that either none or an insubstantial portion of the weight of the user is supported by the forefoot, and with at least a portion of at least one wheel extended below the bottom of a sole of the heeling apparatus through an opening in a heel portion of the sole by using the at least one wheel of the heeling apparatus to contact the surface, wherein the at least one wheel is operable to roll while supporting at least a portion of the weight of the user; and

transitioning from rolling on the surface to either running, walking, or stopping on the surface by placing at least a portion of the forefoot of the heeling apparatus in contact with the surface.

2. The method of claim 1, further comprising:

walking on the surface while wearing the heeling apparatus with at least the portion of the wheel of the heeling apparatus extended below the bottom of the sole through the opening in the heel portion of the sole of the heeling apparatus before moving on the surface.

3. The method of claim 2, wherein the surface includes a decline.

4. The method of claim 2, further comprising:

engaging the at least one wheel of the heeling apparatus so that at least the portion of the at least one wheel extends below the bottom of the sole of the heeling apparatus before walking on the surface.

5. The method of claim 4, further comprising:

walking on the surface while wearing the heeling apparatus before engaging the at least one wheel of the heeling apparatus and with the wheel of the heeling apparatus retracted.

6. The method of claim 2, wherein wearing the heeling apparatus includes wearing a heeling apparatus on each foot of the user.

7. The method of claim 6, wherein rolling on the surface includes placing one heeling apparatus in front of another heeling apparatus.

8. The method of claim 2, wherein walking on the surface includes walking with the at least one wheel extended partially below the bottom of the sole such that the wheel is not readily visible when walking.

9. The method of claim 2, further comprising:

inserting a removable wheel in the opening in the heel portion of the sole before walking on the surface.

- 10. The method of claim 1, further comprising:  
slowing rolling by contacting the forefoot portion of the sole of the heeling apparatus to contact the surface.
- 11. The method of claim 1, further comprising:  
slowing rolling by contacting the heel portion of the sole of the heeling apparatus to contact the surface.
- 12. The method of claim 1, wherein the opening heeling apparatus includes at least a second wheel operable to roll that is positioned in a second opening, the second opening at least partially in an arch portion of the sole.
- 13. The method of claim 1, wherein the heeling apparatus includes at least a second wheel operable to roll that is positioned in the opening, and wherein the opening is at least partially in an arch portion of the sole.
- 14. The method of claim 1, wherein the opening is at least partially in an arch portion of the sole.
- 15. The method of claim 1, wherein moving on a surface includes walking on the surface.
- 16. The method of claim 1, wherein moving on a surface includes running on the surface.
- 17. The method of claim 1, further comprising:  
transitioning from moving on the surface to rolling on the surface by elevating the forefoot portion of the sole of the heeling apparatus.
- 18. A method for transitioning from a walking state or a running state to a rolling state, comprising:  
walking on a surface using at least a portion of a forefoot of a footwear, a sole of the footwear having a heel portion with an opening formed in a bottom surface of the heel portion of the sole; and  
rolling on the surface using at least one wheel operable to rotate in the opening formed in the bottom surface of the heel portion of the sole of the footwear, wherein the at least one wheel is operable to roll while supporting a portion of the weight of a user, and the transitioning from the walking state to the rolling state includes elevating the forefoot relative to the surface such that either none or an insignificant of the footwear relative to the surface such that either none or an insubstantial portion of the user's weight is supported by the forefoot; so that the at least one wheel operable to rotate in the opening formed in the bottom surface of the heel portion of the sole of the footwear contacts the surface.
- 19. The method of claim 18, further comprising:  
running on the surface using at least the forefoot portion of the sole of the footwear; and  
rolling on the surface using the at least one wheel operable to rotate in the opening formed in the bottom surface of the heel portion of the sole of the footwear.
- 20. The method of claim 18, wherein the footwear includes a first footwear provided on a first foot of the user and a second footwear provided on a second foot of the user, and wherein rolling on the surface includes placing the first

- footwear in a position advanced forward relative to the second footwear.
- 21. The method of claim 20, further comprising:  
contacting the forefoot portion of the sole of the first footwear on the surface;  
stepping forward with the second footwear and contacting the surface with the at least one wheel operable to rotate in the opening formed in the bottom surface of the heel portion of the sole of the second footwear;  
pushing forward from the forefoot portion of the sole of the first footwear in contact with the surface; and  
contacting the surface with the at least one wheel operable to rotate in the opening formed in the bottom surface of the heel portion of the sole of the first footwear.
- 22. The method of claim 18, wherein elevating the forefoot portion of the sole includes a shift of the weight of the user from the forefoot portion of the sole of the footwear to the heel portion of the sole of the footwear.
- 23. The method of claim 18, wherein the at least one wheel is removable and further comprising:  
inserting the at least one wheel in the opening formed in the bottom surface of the heel portion of the sole of the footwear before walking on the surface.
- 24. The method of claim 18, wherein the at least one wheel is removable and further comprising:  
removing the wheel in the opening formed in the bottom surface of the heel portion of the sole of the footwear after rolling on the surface.
- 25. The method of claim 18, further comprising:  
contacting the forefoot portion of the sole of the footwear on the surface after rolling on the surface so as to cease rolling.
- 26. The method of claim 18, further comprising:  
contacting a portion of the heel portion of the sole of the footwear on the surface after rolling on the surface so as to slow rolling.
- 27. A method for transitioning from a stationary state to a rolling state, comprising:  
contacting at least a portion of a forefoot of a footwear on a surface, a sole of the footwear having a heel portion with an opening formed in a bottom surface of the heel portion of the sole;  
relative to the surface such that either none or an elevating the forefoot portion of the sole of the footwear relative to the surface such that either none or an insubstantial portion of the user's weight is supported by the forefoot; and  
rolling on the surface using at least one wheel operable to rotate in the opening formed in the bottom surface of the heel portion of the sole of the footwear while supporting at least the portion of a user's weight.

\* \* \* \* \*

UNITED STATES PATENT AND TRADEMARK OFFICE  
CERTIFICATE OF CORRECTION

PATENT NO. : 6,406,038 B2  
DATED : June 18, 2002  
INVENTOR(S) : Roger R. Adams

Page 1 of 1

It is certified that error appears in the above-identified patent and that said Letters Patent is hereby corrected as shown below:

Column 15,

Line 38, after "forefoot", insert -- of the footwear --.

Line 39, delete "of the footwear relative".

Line 40, delete "to the surface such that either none or an insubstantial".

Line 42, replace ";" with -- and --.

Column 16,

Line 44, delete "relative to the surface such that either none or an".

Signed and Sealed this

Sixteenth Day of July, 2002

Attest:

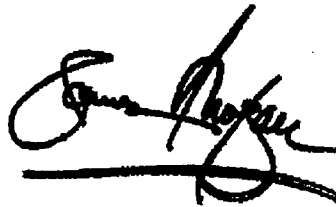

Attesting Officer

JAMES E. ROGAN  
Director of the United States Patent and Trademark Office



**EXHIBIT "B"**

(12) **United States Patent**  
Adams

(10) Patent No.: **US 6,739,602 B2**  
(45) Date of Patent: **\*May 25, 2004**

(54) **HEELING APPARATUS AND METHOD**

(75) Inventor: Roger R. Adams, The Colony, TX (US)

(73) Assignee: Heeling Sports Limited, Carrollton, TX (US)

(\* ) Notice: Subject to any disclaimer, the term of this patent is extended or adjusted under 35 U.S.C. 154(b) by 0 days.

This patent is subject to a terminal disclaimer.

(21) Appl. No.: 10/071,931

(22) Filed: Feb. 7, 2002

(65) **Prior Publication Data**

US 2002/0074748 A1 Jun. 20, 2002

**Related U.S. Application Data**

(63) Continuation of application No. 09/540,125, filed on Mar. 31, 2000, now Pat. No. 6,450,509.

(60) Provisional application No. 60/127,459, filed on Apr. 1, 1999.

(51) Int. Cl.<sup>7</sup> ..... A63C 17/08

(52) U.S. Cl. .... 280/11.19; 280/11.27; 280/11.24; 280/11.223

(58) Field of Search ..... 280/11.24, 11.223, 280/11.27, 11.227, 843, 825, 841, 11.232, 11.226, 11.25, 11.19; 36/115, 116; 301/5.301, 5.303, 5.305

(56) **References Cited**

**U.S. PATENT DOCUMENTS**

132,474 A 10/1872 Lindley

202,191 A 4/1878 Proctor  
234,030 A 11/1880 Hadley et al.  
508,617 A \* 11/1893 Hoerle ..... 280/11.27  
579,577 A 3/1897 Hanscom  
702,476 A 6/1902 Price

(List continued on next page.)

**FOREIGN PATENT DOCUMENTS**

AT	309567 A	10/1918	.....	280/11.227
AU	Des. 137579	6/1999		
CA	1-138-194	12/1982	.....	36/6
CA	1-239-017	7/1988	.....	36/6
CA	2258978	7/2000		

(List continued on next page.)

**OTHER PUBLICATIONS**

Pending U. S. patent application Ser. No. 10/071,931 entitled "Heeling Apparatus and Method" filed Feb. 7, 2002, Inventor : Roger R. Adams, Attorney Docket No. 85353.103.

(List continued on next page.)

*Primary Examiner*—Brian L. Johnson

*Assistant Examiner*—J. Allen Shriver

(74) *Attorney, Agent, or Firm*—Robert J. Ward; Hunton & Williams LLP

(57) **ABSTRACT**

A heeling apparatus includes a shoe with a unique feature in the heel that allows one to walk, run, or roll seamlessly. The appearance is that of normal footwear because of the covert wheel assembly. The stealth wheel in the heel gives one the ability to roll or slide in areas you could only walk. Heeling is a new activity that employs a unique method of rolling and requires a newly learned skill set of balance, positioning, and coordination.

16 Claims, 10 Drawing Sheets

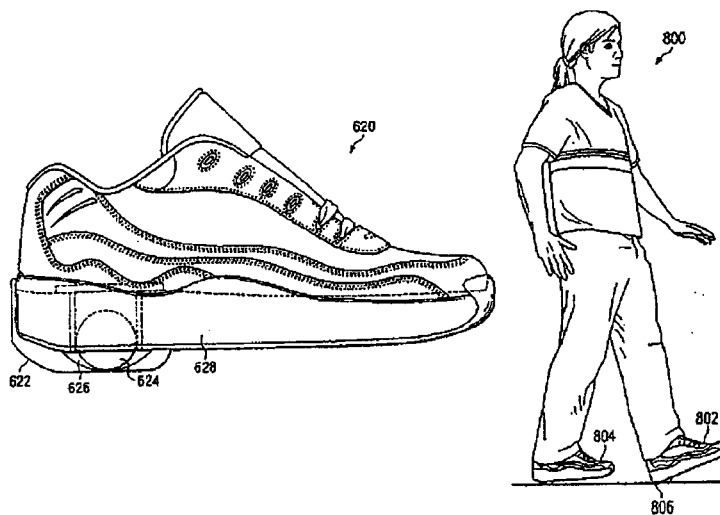

U.S. PATENT DOCUMENTS

875,560 A	12/1907	Vaughan	4,417,737 A	11/1983	Suroff	280/11.115
881,079 A	3/1908	Jolitz	4,442,614 A	4/1984	Farberov	36/103
892,152 A	6/1908	Harman	4,496,025 A	1/1985	Gattman	182/121
966,821 A	8/1910	Gaw	4,523,767 A	6/1985	Le Page	280/11.19
1,051,880 A	2/1913	Glenn	4,638,575 A	1/1987	Illustrato	36/38
1,056,091 A	3/1913	Dickson	4,676,010 A	6/1987	Cheskin	36/32 R
1,068,575 A	7/1913	Demorey et al.	4,691,453 A	9/1987	Tifre	36/8.3
1,189,329 A	7/1916	Winagle	4,699,390 A	10/1987	Cote	280/11.23
1,260,901 A	3/1918	Hayhurst	4,763,909 A	8/1988	Bergeron	280/11.25
1,369,849 A	3/1921	Spencer	4,783,910 A	11/1988	Boys, II et al.	36/107
1,428,232 A	9/1922	Holmen	4,795,181 A	1/1989	Armstrong	280/87.04 A
1,592,692 A	7/1926	Hackett	4,817,974 A	4/1989	Bergeron	280/11.2
1,600,075 A	9/1926	Stoops	4,841,648 A	6/1989	Shaffer et al.	36/43
1,636,909 A	7/1927	Haney	4,843,741 A	7/1989	Yung-Mao	36/114
1,702,591 A	2/1929	Brown	4,887,824 A	8/1989	Hawkes et al.	D21/227
1,866,006 A	7/1932	Bergstrand	4,897,939 A	12/1989	Zatlin	280/87.042
1,975,661 A	10/1934	Powell	4,928,982 A	2/1990	Harrington	36/108
1,984,989 A	12/1934	Reed	4,947,560 A	5/1990	Logan	280/11.22
2,060,391 A	11/1936	Castagnola	4,977,691 A	8/1990	Fuerst et al.	36/88
2,095,942 A	10/1937	Wetterstrand	4,988,122 A	12/1990	Orchard, 3rd	36/44
2,113,477 A	4/1938	Gilman	5,056,240 A	1/1991	Saunders	280/841
2,114,461 A	4/1938	Agosta et al.	5,134,791 A	10/1991	Shemill	36/7.3
2,114,790 A	4/1938	Venables	5,249,376 A	8/1992	Gregory	36/107
2,138,823 A	12/1938	Werkman	D341,179 S	10/1993	Capria	36/115
2,165,581 A	7/1939	Schroeder	5,286,043 A	11/1993	Evaas, III	D21/226
D117,918 S	12/1939	Brodick	5,319,866 A	2/1994	Tkaczyk	280/11.22
D146,368 S	2/1947	McCaffrey	5,319,869 A	6/1994	Foley et al.	36/91
2,422,228 A	6/1947	Ferrari	D352,818 S	6/1994	McDonald et al.	36/114
2,476,806 A	7/1949	Brandt, Jr.	5,372,383 A	11/1994	Bailey	D2/919
2,484,935 A	10/1949	De Rooy	5,384,973 A	12/1994	Kublerschky	280/842
2,490,469 A	12/1949	Pittman	5,388,350 A	1/1995	Lyden	36/25 R
D161,557 S	1/1951	Walker et al.	5,392,537 A	2/1995	Parker, Jr.	36/115
2,572,671 A	10/1951	Shaw	5,393,077 A	2/1995	Goldberg	36/134
2,723,467 A	11/1955	Cassidy	5,396,675 A	2/1995	Wanous	280/7.13
2,897,609 A	8/1959	Bodkin	5,398,970 A	3/1995	Vincent et al.	12/142 P
3,010,732 A	11/1961	Correll	5,410,821 A	3/1995	Tucky	280/841
3,027,661 A	4/1962	McCord	5,417,444 A	5/1995	Hilgendorf	36/100
3,032,894 A	5/1962	Kennedy et al.	5,425,186 A	5/1995	Chen	280/87.042
3,112,119 A	11/1963	Sweet	5,511,824 A	6/1995	Hoyt	36/97
3,176,416 A	4/1965	Seegert	5,527,049 A	4/1996	Kim	280/841
3,306,623 A	2/1967	Weitzner	5,527,050 A	6/1996	Ortiz	280/11.2
3,351,353 A	11/1967	Weitzner	D373,674 S	6/1996	Szendel	280/11.22
3,374,002 A	3/1968	Lewis	5,572,804 A	9/1996	Dolinsky	D2/956
3,476,399 A	11/1969	Finn	5,595,004 A	11/1996	Skaja et al.	36/29
3,478,447 A	11/1969	Gillead	5,632,104 A	1/1997	Lyden et al.	36/29
3,486,250 A	12/1969	Purtle	5,638,614 A	5/1997	Zohar	36/88
3,789,523 A	2/1974	Rubin	5,655,316 A	6/1997	Hardy	36/113
D231,999 S	7/1974	Engman	5,682,685 A	8/1997	Huang	36/132
D233,619 S	11/1974	Kelling	5,682,685 A	11/1997	Terlizzi	36/8.3
3,876,217 A	4/1975	Copier	5,697,643 A	12/1997	Marasco et al.	280/825
3,884,485 A	5/1975	Wille	5,716,074 A	2/1998	Theodorou	280/843
3,934,359 A	1/1976	Fletcher	5,716,723 A	2/1998	Van Cleef et al.	428/690
3,963,251 A	6/1976	Miano	5,730,467 A	3/1998	Huang	280/843
3,983,643 A	10/1976	Schreyer et al.	5,769,432 A	6/1998	Tybinkowski et al.	280/11.2
3,997,179 A	12/1976	de Blois	5,785,327 A	7/1998	Gallant	280/11.27
4,088,334 A	5/1978	Johnson	5,797,609 A	8/1998	Fichepain	280/11.19
4,095,817 A	6/1978	Cohen	5,823,913 A	10/1998	Aruin et al.	482/4
D250,492 S	12/1978	Kish	5,836,591 A	11/1998	Roderick et al.	280/11.22
4,133,548 A	1/1979	Smith	5,839,737 A	11/1998	Kruczek	280/11.115
4,138,127 A	2/1979	Kimmell et al.	D401,739 S	12/1998	James	D2/946
4,149,735 A	4/1979	Blackburn et al.	D402,797 S	12/1998	Kracke	D2/948
4,150,497 A	4/1979	Weber	D404,550 S	1/1999	James	D2/960
4,183,547 A	1/1980	Cohen et al.	5,881,413 A	3/1999	Throneburg et al.	12/133 B
4,219,240 A	8/1980	Brandenstein et al.	5,882,018 A	3/1999	Petrosino	280/7.13
4,245,406 A	1/1981	Landay et al.	5,885,500 A	3/1999	Tawney et al.	264/154
4,295,655 A	10/1981	Landay et al.	5,887,898 A	3/1999	Petrosino	280/825
4,303,253 A	12/1981	Rottenkolber	D408,123 S	4/1999	James	D2/969
4,316,334 A	2/1982	Hunt	5,927,729 A	7/1999	Di Filippo et al.	280/11.3
4,333,249 A	6/1982	Schaefer	5,927,734 A	7/1999	Horton, II et al.	280/87.042
4,364,187 A	12/1982	Melendez	D412,778 S	8/1999	James	D2/951
			D412,779 S	8/1999	James	D2/957

D413,193 S	8/1999	James	D2/947
D414,021 S	9/1999	James	D2/951
D414,320 S	9/1999	Brent	D2/969
5,951,049 A	9/1999	Calverley et al.	280/825
5,967,552 A	10/1999	Roderick et al.	280/843
5,970,631 A	10/1999	Inman	36/115
5,988,656 A	11/1999	Krah	280/11.27
5,997,105 A	12/1999	Wu	301/124.1
6,006,450 A	12/1999	Hayes	36/107
6,006,451 A	12/1999	Morris et al.	36/115
D420,789 S	2/2000	James	D2/962
6,041,525 A	3/2000	Kelley	36/115
6,050,357 A	4/2000	Staelin et al.	180/65.1
6,061,930 A	5/2000	Zinovieff	36/115
D426,374 S	6/2000	Kelley	D2/968
D426,948 S	6/2000	James	D2/968
6,070,887 A	6/2000	Cornelius et al.	280/11.27
6,092,305 A	7/2000	Troy et al.	36/3 B
6,115,946 A	9/2000	Morris et al.	36/115
6,120,039 A	9/2000	Clementi	280/11.19
6,132,006 A	10/2000	Post	301/5.306
D433,214 S	11/2000	McDowell	D2/957
6,151,806 A	11/2000	Morris et al.	36/136
6,158,150 A	12/2000	Morris et al.	36/115
6,195,918 B1	3/2001	Kelley et al.	36/115
6,195,920 B1	3/2001	Morris et al.	36/132
D440,386 S	4/2001	James	D2/968
6,213,480 B1	4/2001	Rodriguez	280/11.204
6,226,900 B1	5/2001	Mazars	36/132
6,243,972 B1	6/2001	De France	36/117.1
6,247,251 B1	6/2001	James	36/115
6,247,708 B1	6/2001	Hsu	280/11.223
6,250,656 B1	6/2001	Ibarra	280/87.041
6,308,964 B1	10/2001	Chang	280/11.19
6,336,644 B1	1/2002	Chu	280/11.233
6,354,609 B1	3/2002	Chen et al.	280/11.3
6,357,145 B1	3/2002	James	36/115
6,386,555 B1	5/2002	Kao	280/7.13
6,406,038 B2	6/2002	Adams	280/11.24
6,412,791 B1	7/2002	Chu	280/11.19
6,450,509 B2	9/2002	Adams	280/11.24
6,467,198 B1	10/2002	James	36/115
6,488,289 B2	12/2002	Hsiao et al.	280/11.208
6,536,785 B2	3/2003	Lee	280/11.27

FOREIGN PATENT DOCUMENTS

CA	2258980	7/2000	
CN	85 2 04333 U	10/1986	
CN	ZL 97244602.8	10/1997	
DE	254775	5/1912	
DE	456796	3/1928	280/843
DE	723 266	5/1939	
DE	723266	8/1942	
DE	821-323	7/1949	
DE	204456	7/1959	
DE	2321669 A	3/1974	
DE	2550211	5/1976	
DE	28 21 644	5/1978	
DE	29613508 U1	10/1996	A63C/17/00
DE	197 55 340 A1	6/1999	A63C/17/20
DE	20023053.0	10/2002	
FR	1194886 A	11/1959	

FR	2196826	3/1974	A63C/17/20
FR	2 291 715	11/1974	
GB	2297	6/1877	280/11.24
GB	117176	7/1918	
GB	150512 A	9/1920	
GB	216903 A	1/1925	
GB	2363562	11/2002	
JP	368449	9/1930	
JP	17-3781	3/1942	
JP	58-142078	8/1983	
JP	63-135673	6/1988	
JP	5-40721	2/1993	
KR	90-11303	3/1988	
WO	WO 92/05845	4/1992	A63C/17/24
WO	WO 95/20424	8/1995	A63C/17/20
WO	WO 98/01051	1/1998	A43B/23/00
WO	WO 02/11831	2/2002	

OTHER PUBLICATIONS

Pending U. S. patent application Ser. No. 10/071,597 entitled "Heeling Apparatus and Method" filed Feb. 7, 2002, Inventor: Roger R. Adams, Attorney Docket No. 85353.90.

Pending U. S. patent application Ser. No. 10/357,998 entitled "Grind Rail Apparatus" filed Feb. 3, 2003, Inventor: Roger R. Adams, Michael G. Staffaroni, Attorney Docket No. 85353.251.

Pending U. S. patent application Ser. No. 10/357,776 entitled "Shock Absorption System For A Sole" filed Feb. 3, 2003, Inventor: Michael G. Staffaroni, Jong S. Choi, Attorney Docket No. 85353.252.

Pending U. S. patent application Ser. No. 10/357,765 entitled "Multi-Wheel Heeling Apparatus" filed Feb. 3, 2003, Inventor: Roger R. Adams, Michael G. Staffaroni, Attorney Docket No. 85353.254.

Pending U. S. patent application Ser. No. 10/369,063 entitled "External Wheeled Heeling Apparatus and Method" filed Feb. 18, 2003, Inventor: Roger R. Adams, Attorney Docket No. 85353.255.

Pending U. S. patent application Ser. No. US 2001/0022433 entitled "Wheel Assembly for a Roller Skate" filed May 31, 2001, Inventor: Chun-Chen Chang, Published: Sep. 20, 2001.

U.S. Patent Application Publication No. US 2002/0125655, entitled "Bi-functional Roller Skate" filed Mar. 9, 2001, Inventor: Chun-Chung Hsiao, Published Sep. 12, 2002.

U.S. Patent Application Publication No. US 2003/0062697, entitled "Multifunctional Shoe" filed Oct. 3, 2001, Inventor: Wei-Yen Chu, Published Apr. 3, 2003.

Article in "Bulletin Board," Digital bytes and buzz, which contains an ad for "Street Flyers."

Advertisement for "Street Flyers" at the Internet website for FAO Schwartz, [www.fao.com/faoschwartz/streeflyers.html](http://www.fao.com/faoschwartz/streeflyers.html) dated Dec. 17, 1999.

Advertisement for "Street Flyers" at the Internet website for StreetFlyers, [www.streeflyers.com/cgi-bin/ncommerce3/ExecMacro/home.d2w/report](http://www.streeflyers.com/cgi-bin/ncommerce3/ExecMacro/home.d2w/report) dated Jan. 24, 2000.

\* cited by examiner

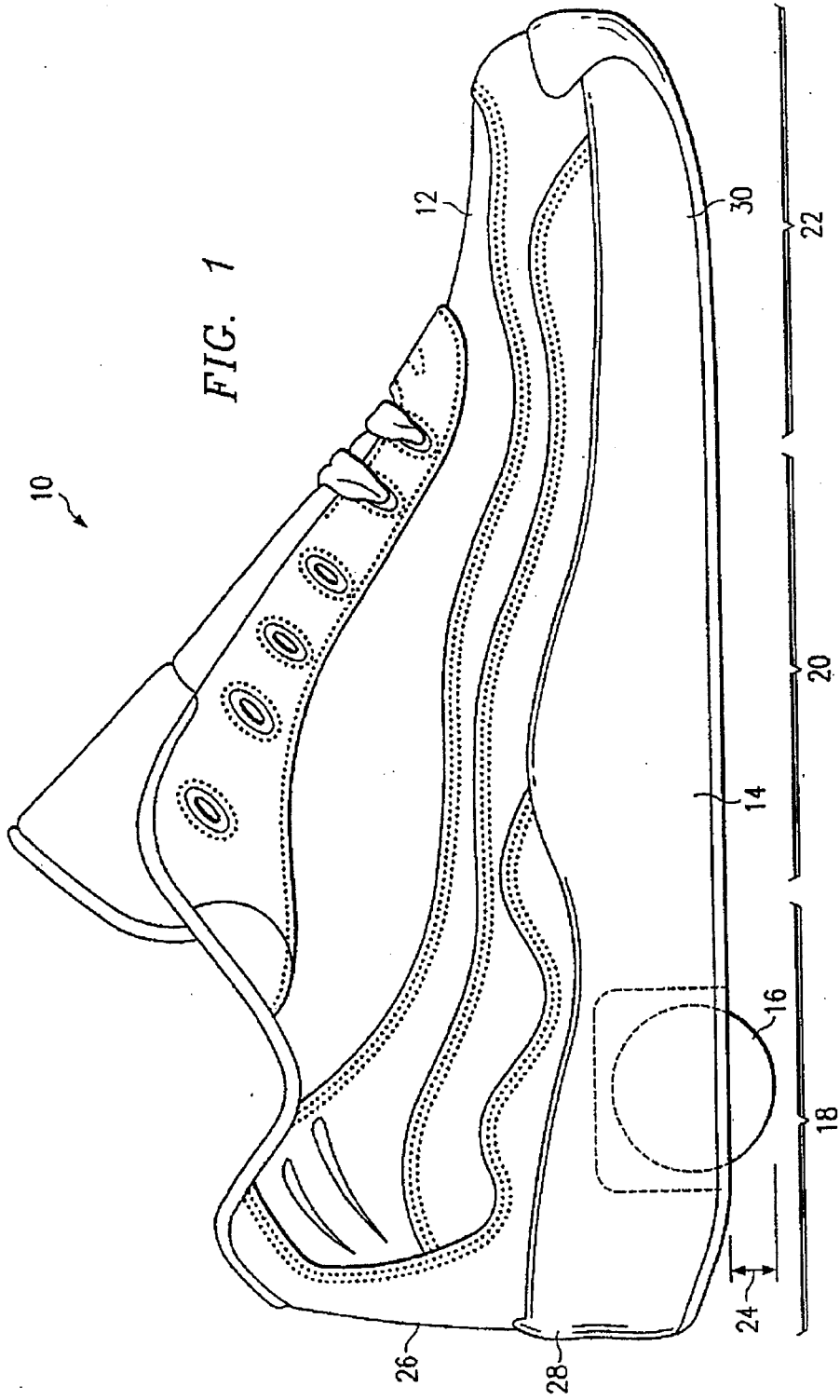

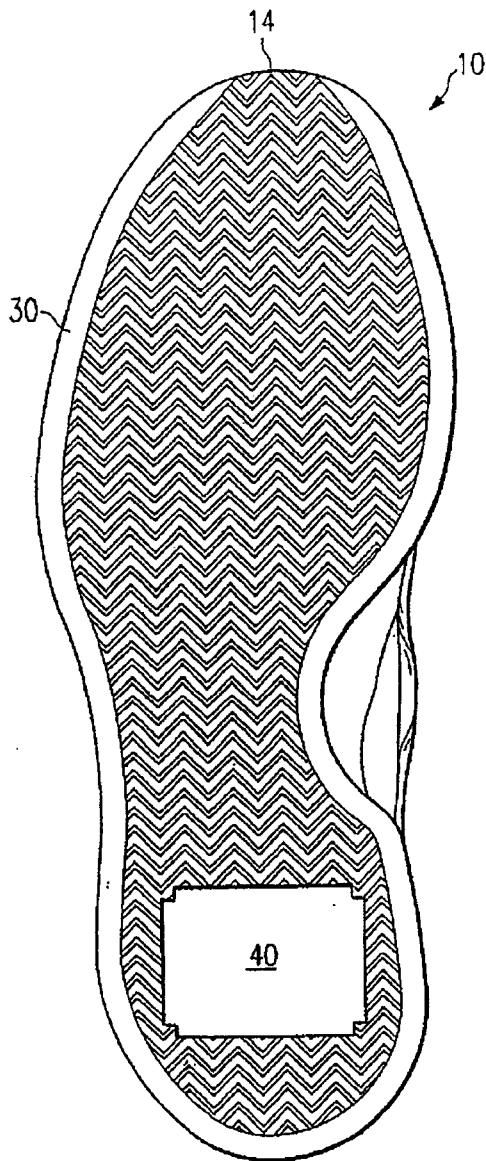

FIG. 2A

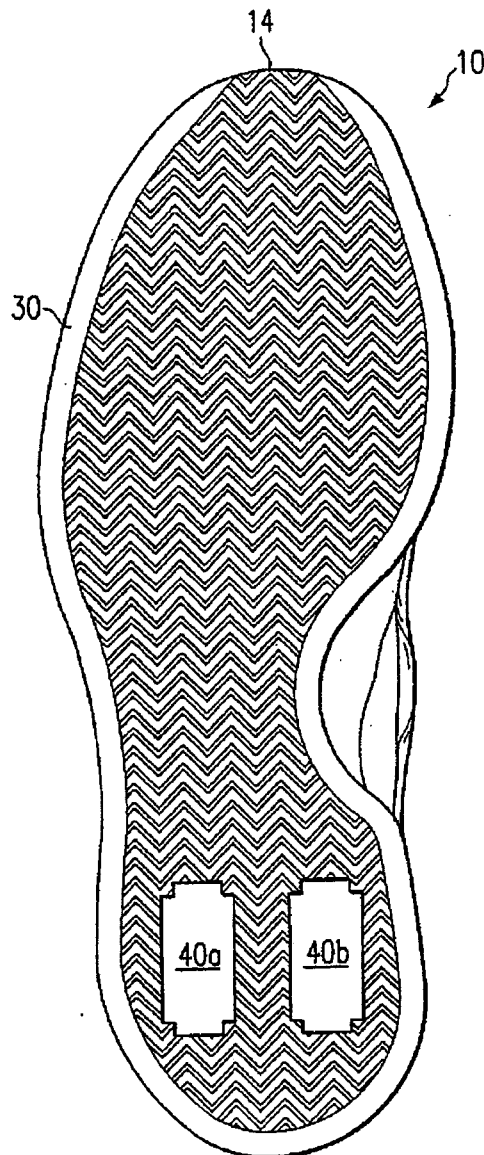

FIG. 2B

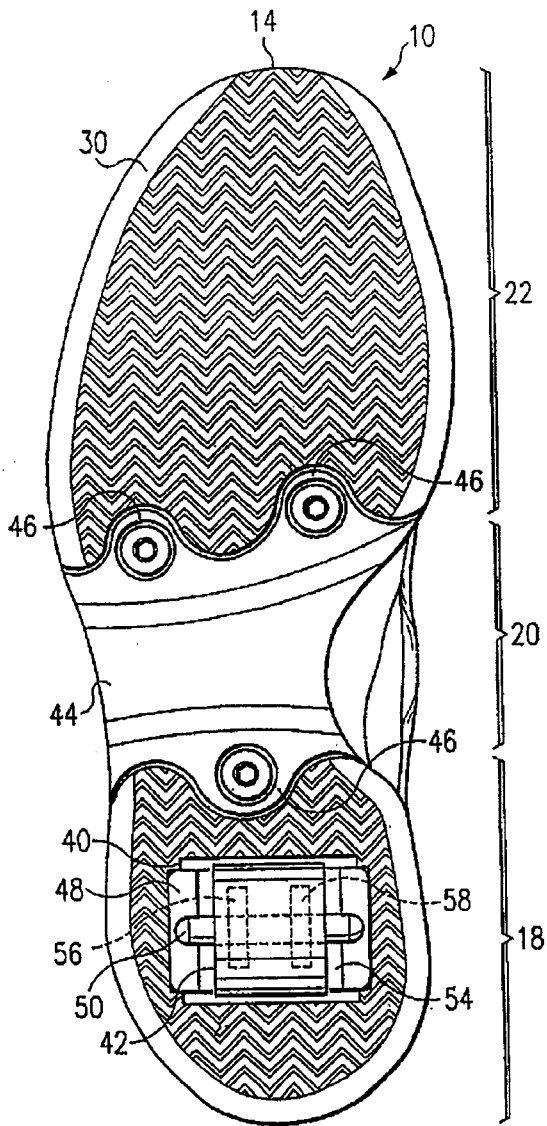

FIG. 3A

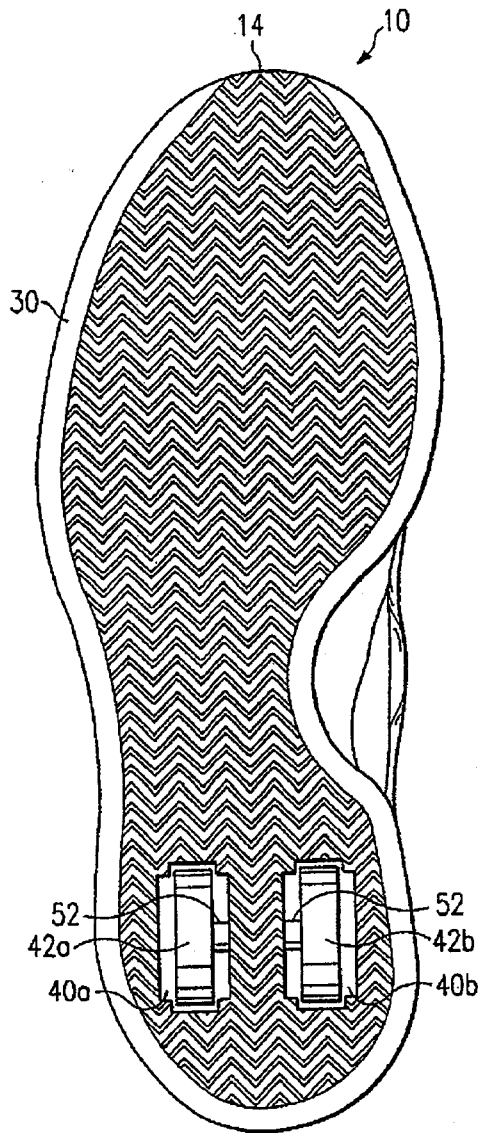
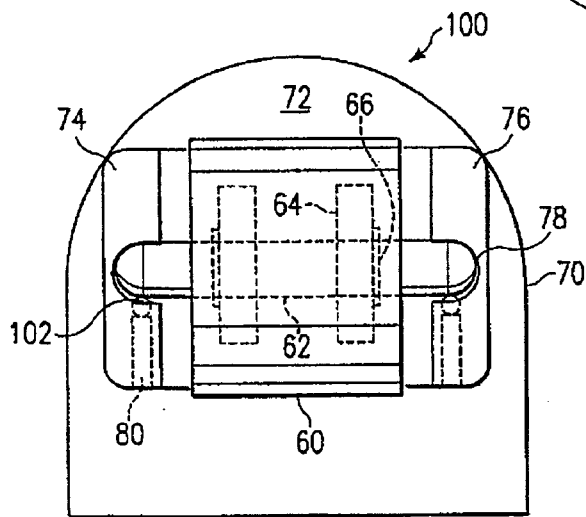
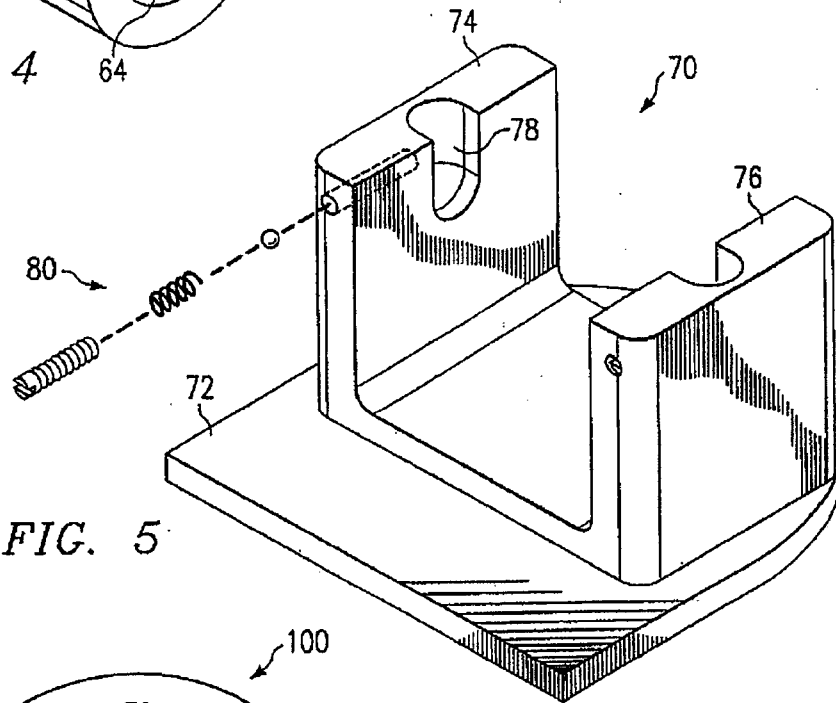
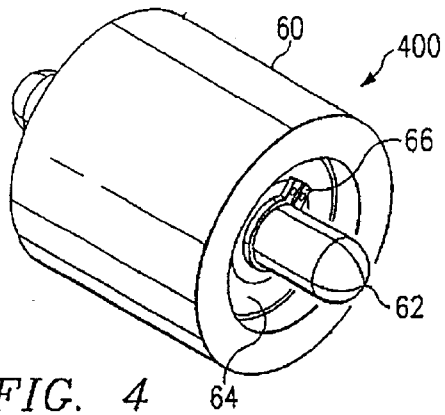

FIG. 3B



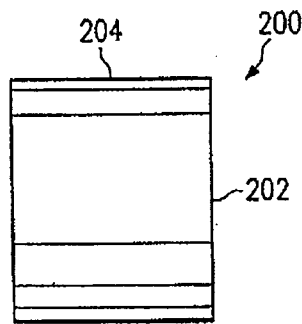
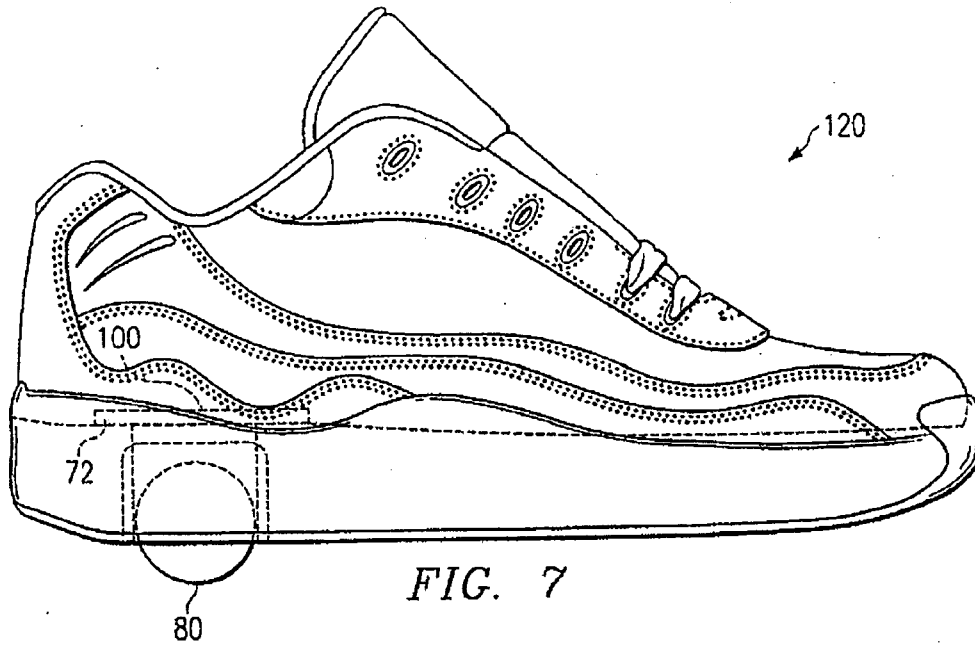

FIG. 8A

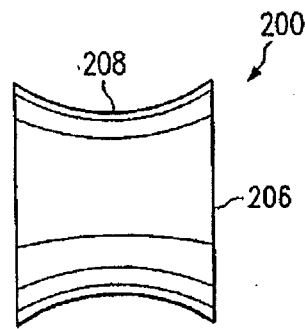

FIG. 8B

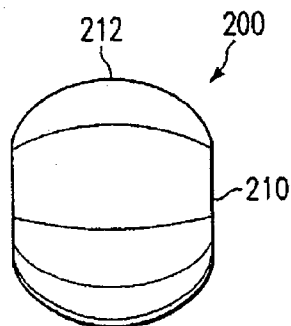

FIG. 8C

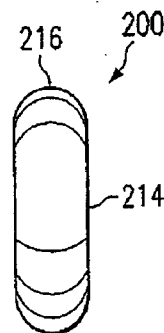

FIG. 8D

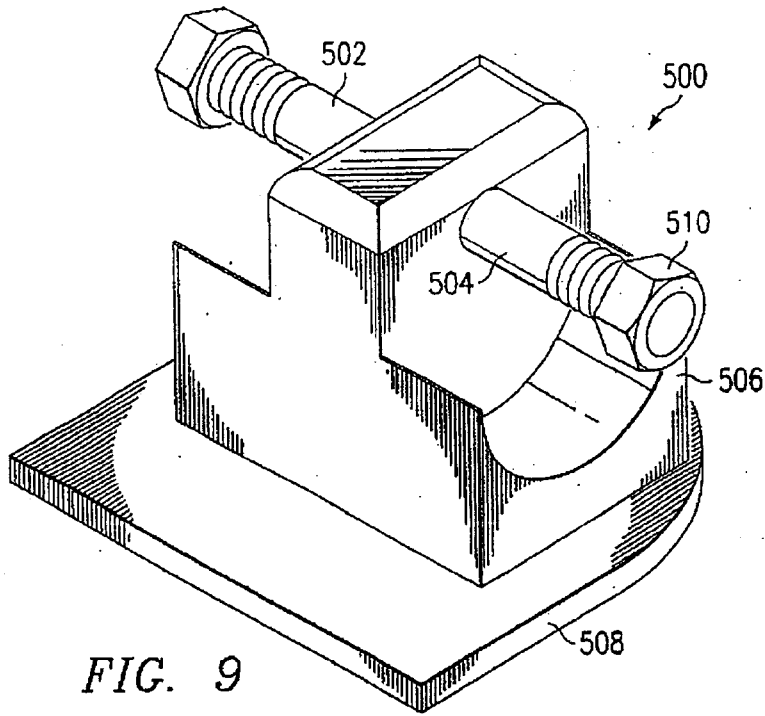

FIG. 9

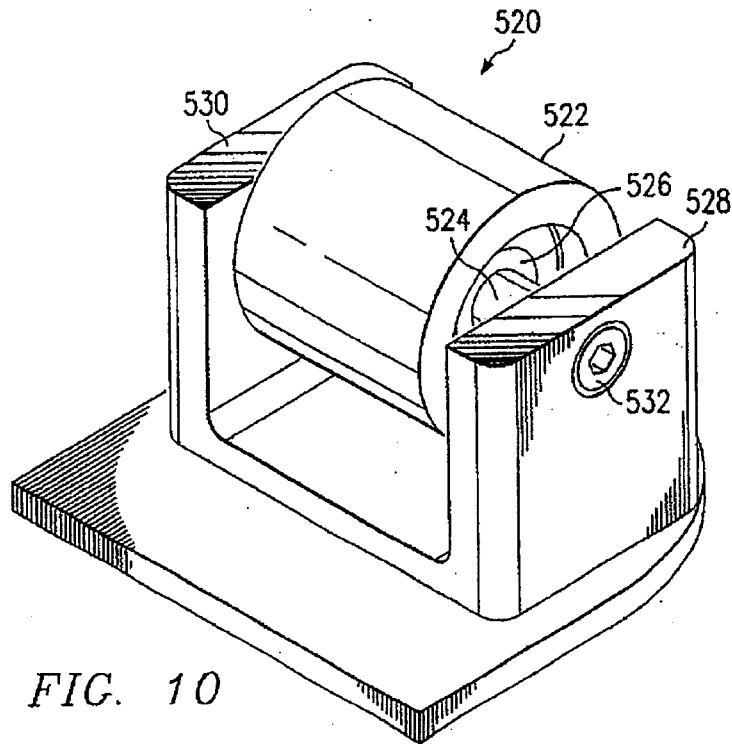

FIG. 10